

Pt-100 Measuring Transducer

AD-MV 50 GX
AD-MV 54 GX

Description

The data amplifier AD-MV 50 GX (for 2/3-conductor method) or AD-MV 54 GX (for 4-conductor system) transforms the measuring signal, emitted from a resistance transducer Pt 100 (acc. to DIN IEC 751) to an impressed output signal (e.g. 0-20 mA). The output characteristic is read out temperature linear. When using the 3-/4-conductor switching, conductor resistances up to 100 Ohm are out compensated. In 2-conductor switching, a subsequent zero or full compensation via trim potentiometers at the front is possible. The analogue output signal is separated galvanically from the supply voltage.

In combination with a narrow overall width of 6.2 mm, a high packing density is achieved.



Application

Temperature measuring with Pt 100 in the required temperature range, for continuous indication of temperature entities.

Specification

construction	1-channel switchboard housing 6,2 x 92 x 101 mm (WxHxD)
power-supply	18-30 VDC internal galvanically isolated
power consumption	ca. 850 mW
input:	resistance sensor Pt 100 (DIN IEC 751) AD-MV 50 GX 2- or 3-wire connection technology AD-MV 54 GX 4-wire connection technology
input temp. range:	according to customer specifications, for example: -20...+140°C (max. measuring range -200...+800°C)
output:	0-20 mA, 4-20 mA, 0-10 V DC, according to customer specifications
output burden	max. 400 Ohm bei Stromausgang min. 1 kOhm bei Spannungsausgang
linearity error	< 0,5 %
influence of temperature:	< 100 ppm/K
Protective system:	input/output against over-voltage power supply against over-voltage, over-current and over-temperature
EMC	
product family standard	EN 61326
emitted interference	EN 55011, CISPR11 Cl. A industry
electrical safety requirements	
product family standard	EN 61010-1

Connections and dimensions:

AD-MV 50 GX (Pt-100, 2-/3-wire system)
AD-MV 54 GX (Pt-100, 4-wire system)

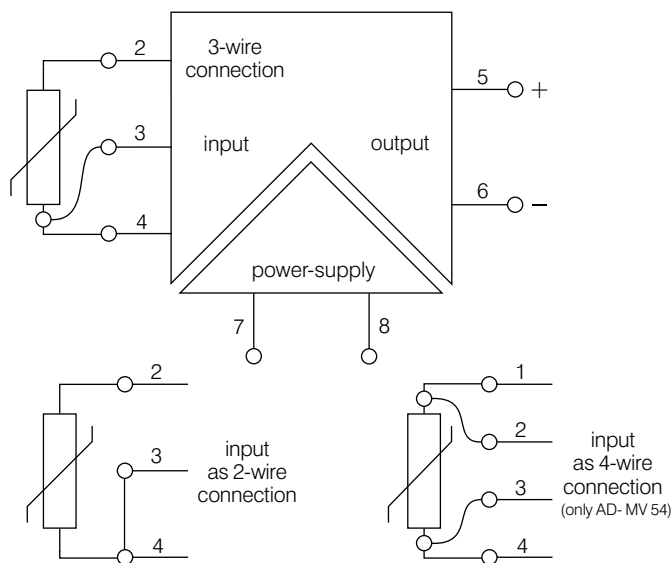

weight: max. 100 g
protection: IP 20

connection data:
fine-wire: 2,5 mm²
single-wire: 4,0 mm²
manner of fastening:
DIN rail 35mm (EN50022)

Printed 05.02.2013. We reserve the right for technical changes



ADAMCZEWSKI
Elektronische Messtechnik GmbH

Felix-Wankel-Str. 13
Tel. +49 (0)7046-875
vertrieb@ad-messtechnik.de

74374 Zaberfeld
Fax +49 (0)7046-7678
www.adamczewski.com