

## Description

The photovoltaic optimizer AD-PVO 6000 monitors the feed of PV energy at the main connection to the building. If the feed conductor exceeds a limiting value, optimized via a PC by the customer, up to three independent load relays can be selected. These three load relays can be parameterized individually and can therefore switch loads either in phases or in steps. With these switching relays, electric consumers (i.e. electric heating rod in the water tank of the heating, air conditioning unit or heat pump), can be selected. With the AD-PVO 6000, the energy is implemented on site, it is not fed back into the public low-voltage network. Through the application of this device, PV units are optimised for personal consumption and the public network is relieved. Additionally, the AD-PCO 6000 has an error-message LED and an integral error message relay, via which error messages (i.e. permanent failure of the feed) can be indicated outside the distributor cabinet or can be signalled acoustically. It is recommended to mount the AD-PVO 6000 directly after the counter of the energy supplier in the distributor cabinet, as measuring should be carried out as close as possible to the feed point. The device requires all three outer conductor voltages and the neutral conductor for its measuring. The AD-PVO 6000 measures the current via three external split core current transformer, which can be mounted space-saving (without separation) directly on the 3 phases after the counter. The photovoltaic optimizer receives the personal consumption energy from the measuring voltage L1. This way, no separate supply voltage must be connected.

## Application

For optimising the self-generated energy at photovoltaic units



## Specific characteristics

- 3 internal overload and 1 fault relay
- Current measurement with clamp on/split core current transformer
- Configuration via PC
- compatible with **SG-Ready** compatible heat pumps

## Business data

Order number AD-PVO 6000

## Technical specifications

### Current-inputs (I1...I3)

Measuring range 0 ... 33 mA AC (0 ... 100 A AC via external current transformer)  
Input resistance ca. 10 Ohm

### Voltage-inputs (L1...L3)

Measuring range 230 V AC (+/- 10 %)  
Input resistance ca. 500 kOhms

### External current-transformer

Primary current 0 ... 100 A AC  
Secondary current 0 ... 33 mA AC  
Transformation ratio 1:3000 (Np : Ns)  
Maximum wire diameter 15 mm  
Max. secondary wire length 2 m  
Isolation-voltage 2,5 kV / 1 min  
Dimensions (WxHxD) 32x42x46 mm

### Load relays (K1 to K3)

Maximum switching load AC 250 V, 9 A  
Maximum switching load DC 50 V, 9 A  
Contact construction closing contact  
Switching operations mechanical 6 000 000  
At 230V/9A AC, cos(phi)=1 400 000  
At 230V/9A AC, cos(phi)=0,4 150 000  
At 24V/9A DC 200 000

### Error-relay

Maximum switching load AC 250 V, 2 A  
Maximum switching load DC 50 V, 2 A  
Contact construction changeover contact  
Switching operations mechanical 10 000 000  
At 230V/2A AC, cos(phi)=1 600 000  
At 230V/2A AC, cos(phi)=0,4 200 000  
At 24V/2A DC 200 000

### Supply

Voltage range AC 230 V AC (+/- 10 %), 50/60 Hz (see voltage-inputs)  
Nominal voltage AC 230 V AC  
Power consumption max. 5 VA

### Transfer behavior - in reference to the current value

Basic accuracy < 1 % (class 1)  
Temperature influence 80 ppm/K  
Response time < 2 s

### Housing

Dimensions (WxHxD) 105x90x58 mm  
Type of protection IP 20  
Connection method screw clamp  
Terminals, wire cross section 2,5 mm<sup>2</sup> flex wire / 4 mm<sup>2</sup> one wire  
Bolting torque terminals 0,6 Nm  
Skinning length 6 mm  
Weight ~ 225 g + 3x 75 g (current-transf.)  
Manner of fastening 35 mm DIN rail 35mm

### Environmental conditions

Ambient temperature 0 ... 50 °C  
Storage and transport -10 ... 70 °C (no thawing)



### Technical specifications

#### EMC

Product family standard	EN 61326 <sup>1)</sup>
Emitted interference	EN 55011, CISPR11 Cl. B

#### Electrical safety requirements

Product family standard	EN 61010-1
Overvoltage category	II
Pollution degree	2
Safety measurement	EN 61010-2-030
Measurement category	CAT III

#### Galvanic isolation, test voltages

Grid side to relay outputs	4 kV, 50 Hz (1 min.)
Grid side to the pc-interface	4 kV, 50 Hz (1 min.)
Grid side to control elements	4 kV, 50 Hz (1 min.)
Load-relay to error-relay	4 kV, 50 Hz (1 min.)

#### Protection circuits

Input	electrical surge protection
Load-relay	spark quenching
Power supply	protection against over-temperature, over-voltage and over-current

<sup>1)</sup> During checking, slight signal deviations are possible.

### Heat pump control

## SG-Ready

With the PV optimizer AD PVO 6000 heat pumps can be signaled that enough PV surplus exists.

Thus, the heat pump can raise their storage or flow temperature and increase the personal consumption.

The optimizer is compatible with many SG-Ready (Smart Grid Ready) enabled heat pumps. The SG-Ready logo can be found on your heat pump.

The SG-ready interface is designed in in most cases as a contact input therefore, the overload relay of the PVO can be used easily as a signal for the temperature increase of the heat pump.

What is to be done at a SG-signal, it must be parameterized on the heat pump.

Through the three internal load relays, the heat pump can switch multiple states. It can be driven so several power levels.

### Block and wiring diagram

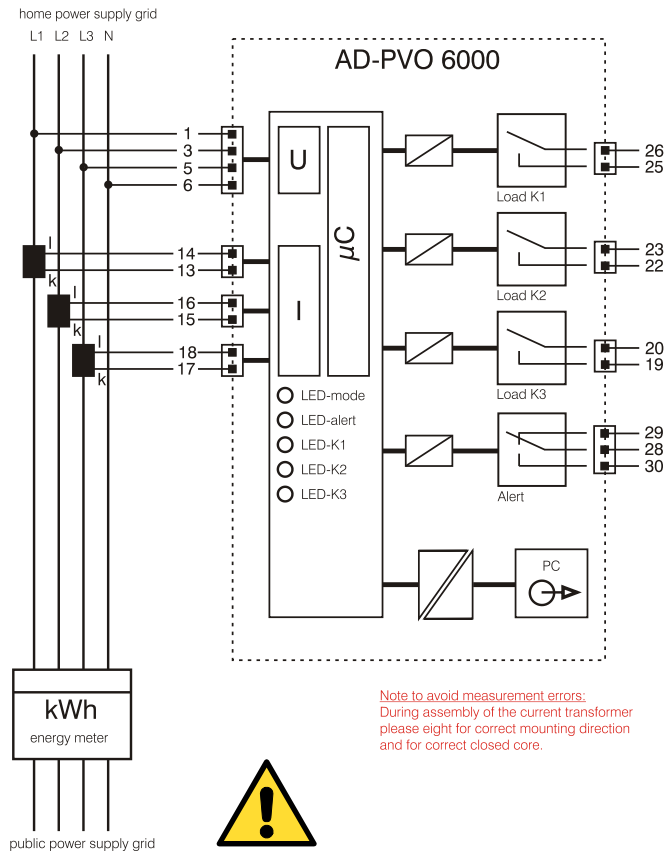

### Dimensions

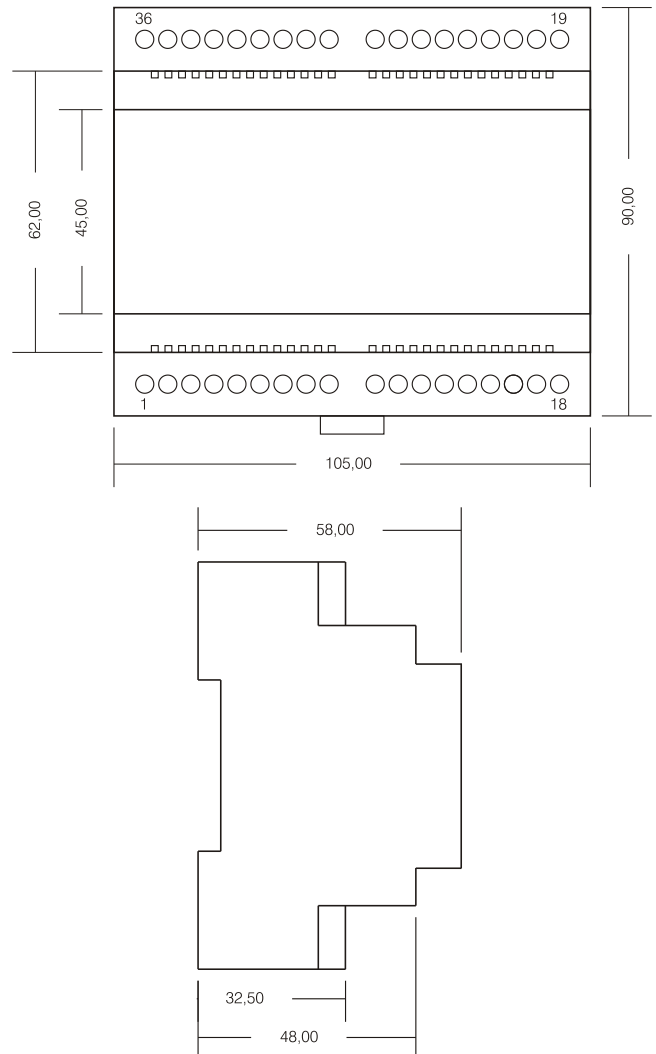

## Operation

### Operating LED

The green operating LED indicates the operating status of the device.

- off: the device has no operating voltage
- permanently on: the device is in normal operation mode
- flashing with 5 Hz: the manual load connection is active

### Relay Status LEDs

- on: the load is connected to the device
- off: no load is connected

### Error LED

The red error LED indicates whether an error is present.

- off: no error
- on: error is present

### Key: Manual load (K1 ... K3)

The buttons "Manual load" serve the manual connection of the load relays. The load is activated with a long depression of the key (2s) and deactivated again the same way.

### Key: Quit

The key "Quit" is provided for quitting an error message. If an error is present, the red error indicator LED lights up and the error message relay responds. An acoustic indicator can be connected at the error message relay, for instance. Now if the key "Quit" is activated, the relay releases again. The red error LED, however, is lit until the error has been eliminated.

### Software and parameterizing

The device can be parameterized and read out with the parameterizing software AD-Studio and the optionally available USB programming adapter AD-VarioPass3. The suitable USB driver for the USB programming adapter AD-VarioPass2 is supplied with the software AD-Studio. With the software, measuring values can also be read out or logged.

For connecting to the PC, the blind plug must be removed from the parameterizing interface (AD-PC), i.e. with a small screwdriver. Push the screwdriver into the slot provided and work the blind plug out.

The following parameters can be edited:

- **Filter:** analogue value filter for the input measuring dimensions. Serves the suppression of quick measuring value alterations.
- **Current transformer type:** Specifies the connected current transformers type (distinguishing primary current).
- **Power of the load (K1 ... K3):** the power consumption at the load relays required by the connected load must be specified here. This specification is required for internal calculations.
- **Switch-on-level (K1 ... K3):** sets the switch-on threshold of the load relay, in reference to the fed power.
- **Switch-off-level (K1 ... K3):** Sets the switch-off threshold of the load relay, in reference to the fed power.
- **Fault injection time:** Sets the time, after which an alarm is triggered when during this set time no feeding has occurred.
- **Plant size:** Sets the plant size in kWp. Only used at 70%-message.
- **Error relay function:** Sets the function of the fault relay. You can choose between two modes: "feed-error" and "70%-message". The standard function "feed error" triggers a fault message after a specified time. This time is set in parameter "Fault injection time". The "70% message" triggers an alarm if all loads of the PVO are switched on and the PV-plant over 70% feeds. It is the "plant size" parameter evaluated.

- **Operation Mode:** Sets the operating mode of the device. In operating mode 0, the three load relays (K1, K2 and K3) are assigned with three output stages (example 500W, 1000W and 1500W) and they react in steps to the fed total output in all three phases. For the smallest switching stage, K1 must be selected and for the largest K3 must be selected.

In operating mode 1, each phase output is viewed separately and in each case one relay reacts to the relevant fed phase output (K1 to power in L1, K2 to power in L2 and K3 to power in L3).

With operating mode 2, three different loads are switched intelligently. That is, all possible combinations of the three loads are switched, to optimally implement the surplus energy. If, for instance, a heating rod has three heating coils with 500W, 1000W and 2000W, this results in seven combinations in steps of 500W. Here also the smallest load must be connected to K1 and the largest load must be connected to K3. In this operating mode, only the load capacity can be parameterized, the possible switching combinations and switching thresholds are calculated automatically.

### Automatic load calibration

For commissioning the AD-PVO 6000, the parameters are normally adjusted via the parameterizing software AD-Studio and the available USB programming adapter AD-VarioPass3. However, an "automatic load calibration" can also be started directly at the device. In this operating mode, the output of the consumer connected to the load relays is automatically calibrated and a PC is not necessary. The load calibration is started with a longer depression of the "Quit-key" (3s). As long as the calibration is running, the two LEDs flash alternately. This process can last up to several minutes. If the calibration is cancelled with a brief depression of the "Quit-key", the values in the parameter are reset to the last status. After successful completion of the "automatic load calibration", the device takes over the measuring data and returns to normal operation. If the load calibration is not completed after approx. 15 minutes, there are too strong load fluctuations in the network. With too strong load fluctuations, the device is difficult to calibrate. Here we recommend to separate these loads briefly from the network during the calibration time, or to parameterize the device via the PC.

### Safety instructions – it is essential to read these



**Explanation of symbols**

Two squares, one inside the other, indicate a DOUBLE or REINFORCED insulation of the device against dangerous high voltages (i.e. mains voltage). This is valid for all parts at the housing, which can be touched, for the operating elements and the low voltages generated by and lead from the device.



**Explanation of symbols**

An exclamation mark inside a triangle indicates important notes in the technical data sheet and in the notes on safety. Read both documents to the end prior to commissioning. They contain important notes for the correct operation and the installation. Non-observation and errors resulting from this can lead to dangers.

**Designated usage**

The device must only be used for the purpose described in the relevant data sheet.  
 The device conforms to the valid CE European guidelines and harmonised standards.  
 Usage in explosion-endangered areas, outdoors or in damp rooms is NOT admissible.  
 The device must only be operated with the specified nominal voltage. The specified switching capacities must not be exceeded.  
 Opening or altering the device is not admissible. Do not repair the device yourself, but replace it with an equivalent new device. Repairs must only be carried out by the manufacturer.  
 The manufacturer accepts no liability due to infringement.  
 An operation under adverse environmental conditions is not admissible.  
 Adverse environmental conditions are:

- high sun radiation
  - wetness, dewing or too high humidity
  - dust and flammable gases, vapours or solvents
  - strong vibrations or electro-magnetic fields
- Do not expose the device to stresses, which exceed the described limits.

Usage other than the one described in the relevant data sheet is not admissible and leads to damage of the product.  
 Furthermore, this is connected with dangers, as for instance short circuit, fire, electric shock etc., which can be fatal.

**Notes on safety and dangers**

Any warranty claim becomes void for damages due to non-observation of these notes on safety and the relevant technical data sheet.

The following points must be noted:

- the valid laws, standards and regulations
- the stand of technology at the time of the installation
- the handbook and/or the technical data sheet
- the recognised rules of technology
- the fact that operating instructions can only state general regulations and that these regulations must be observed
- the device is not a toy and does not belong in the hands of children
- only operate the device with undamaged connection lines.

**Notes on connection and installation**

- WARNING: dangerous electric voltage can lead to electric shock and burns.
- The installation and maintenance must be carried out by qualified electricians.
  - Observe the technical data specified in the data sheet.
  - Provide a correctly dimensioned overcurrent device in the vicinity of the device.
  - Mount the device in an appropriate control box/control cabinet with a suitable type of protection according to IEC 60529 to protect it from mechanical or electrical damages.
  - During maintenance work, cut the device off from all effective sources of energy and secure it against restart.
  - If operating elements of protection class 1 are connected to the contact outputs of the device, the protective earthing conductor connection must be carried out separately and properly.

**ESD**

ATTENTION: When handling the device, protective measures against electrostatic discharge must be observed.

**Maintenance and cleaning**

The device is maintenance-free and does not have to be cleaned.

**Disposal**

Old electronic devices are valuable substances and do not belong into the household waste. If the device has reached the end of its useful life, dispose of the device according to the valid legal regulations.

Status: 09/2013

**Adamczewski**  
 Elektronische Messtechnik GmbH  
 74374 Zaberfeld  
 www.adamczewski.com

### Circuit examples

