

Display device, control unit and data logger

# AD-VL 500 FE

Manual

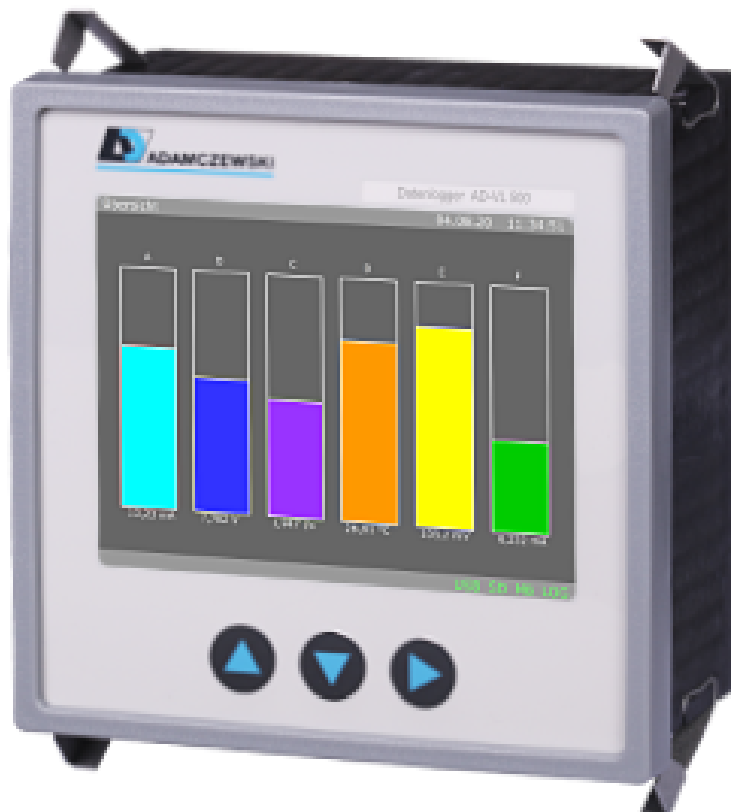

# Contents

<b>1</b>	<b>About this manual</b>	<b>4</b>
1.1	Structure of the warnings . . . . .	4
<b>2</b>	<b>Safety</b>	<b>5</b>
<b>3</b>	<b>Product description</b>	<b>7</b>
3.1	Block diagram . . . . .	8
3.2	Display and operating elements . . . . .	9
3.2.1	Status bars . . . . .	9
<b>4</b>	<b>Technical data</b>	<b>10</b>
4.1	Supply . . . . .	10
4.2	Housing . . . . .	10
4.3	Environmental conditions . . . . .	10
4.4	EMC . . . . .	10
4.5	Electrical safety . . . . .	10
4.6	Analogue inputs . . . . .	10
4.6.1	Current inputs . . . . .	10
4.6.2	Voltage inputs . . . . .	11
4.6.3	Counter . . . . .	11
4.7	Interfaces . . . . .	11
4.7.1	RS485 interface . . . . .	11
4.8	Configuration interface . . . . .	11
4.8.1	Network interface . . . . .	12
4.8.2	USB-Interface . . . . .	12
4.9	Display . . . . .	12
4.10	Operation . . . . .	12
<b>5</b>	<b>Assembly and commissioning</b>	<b>13</b>
<b>6</b>	<b>Operation and menu navigation</b>	<b>14</b>
6.1	Key functions . . . . .	14
6.2	Normal operation . . . . .	14
6.3	Window navigation . . . . .	15
<b>7</b>	<b>Configuration</b>	<b>16</b>
7.1	Analogue channel setup . . . . .	16
7.2	Configuration menu . . . . .	16
7.2.1	Device information . . . . .	16
7.2.2	Analogue inputs . . . . .	17
7.2.3	Windows . . . . .	18
7.2.4	Display elements . . . . .	18
7.2.5	Log channels . . . . .	24
7.2.6	Log settings . . . . .	25
7.2.7	Options . . . . .	28
7.2.8	Network . . . . .	28
7.2.9	RS485 . . . . .	28
7.2.10	Delete files . . . . .	29
7.2.11	Configuration . . . . .	29

7.2.12 Backup to USB . . . . .	29
<b>8 Modbus</b>	<b>30</b>
8.1 Basics . . . . .	30
8.2 AD-VL 500 FE Data register . . . . .	33
8.2.1 Local Modbus register . . . . .	33
8.2.2 Modbus virtual registers . . . . .	34
<b>9 Wiring diagram</b>	<b>35</b>
<b>10 Network connection</b>	<b>37</b>
10.1 Connection . . . . .	37
10.2 Protocols . . . . .	37
10.3 Data security . . . . .	38
10.4 Navigation . . . . .	38
10.5 Homepage . . . . .	39
10.6 Configuration . . . . .	40
10.7 Configuration pages . . . . .	41
10.7.1 Device information . . . . .	42
10.7.2 Analogue inputs . . . . .	43
10.7.3 Configuration windows . . . . .	45
10.7.4 Display elements . . . . .	45
10.7.5 Log channels . . . . .	46
10.7.6 Log settings . . . . .	47
10.7.7 Options . . . . .	48
10.7.8 Configuration files . . . . .	49
10.7.9 Network . . . . .	49
10.7.10 RS485 . . . . .	50
10.8 Find devices in the network . . . . .	51
10.8.1 Automated device call-up . . . . .	51
10.8.2 Manual unit call . . . . .	51
<b>11 Storage management and data formats of the files</b>	<b>52</b>
11.1 Storage space management . . . . .	52
11.2 Data structure . . . . .	52
11.2.1 Memory requirements on the SD card . . . . .	53
11.3 Logfile . . . . .	53
<b>12 Maintenance and servicing</b>	<b>54</b>
12.1 Firmwareupdate . . . . .	54
12.1.1 Firmwareupdate with Configuration software AD-Studio . . . . .	55
12.1.2 Firmware update with USB data carrier . . . . .	55
12.1.3 Firmware update via network (LAN) . . . . .	56
<b>13 Help with faults</b>	<b>57</b>
<b>14 Appendix</b>	<b>58</b>
14.1 Address of the manufacturer . . . . .	58
14.2 Data evaluation . . . . .	58
14.3 Device operating instructions . . . . .	58
14.4 Device data sheet . . . . .	58

# 1 About this manual

This manual is part of the product.

- Read the manual carefully before using the device.
- Keep the manual for the entire service life of the product and have it available for reference.
- Pass the manual on to any subsequent owner or user of the product.

## 1.1 Structure of the warnings



*Please consider the documentation. This symbol is intended to warn you of possible hazards that could arise during assembly, commissioning and use.*

- Here, actions to avoid the danger are available.
- ...

### Structure of the hazard warnings



*Danger to life or serious injury. Disconnect the system and the unit from the power supply before starting work..*

- Here, actions to avoid the danger are available.
- ...

## 2 Safety

### Intended use



*The operating, maintenance and servicing conditions prescribed in this manual must be strictly observed. Maintenance conditions must be strictly adhered to.*

The AD-VL 500 FE is intended for connection to an RS-485 interface to which other devices are connected in bus mode.

The AD-VL 500 FE can be connected to a PC or laptop via the configuration interface.

The AD-VL 500 FE is intended for installation in front panels of control cabinets.

The AD-VL 500 FE has a connection for the supply voltage and can be supplied with AC voltage up to 250V AC or 24V DC.

Any other use is not in accordance with the intended use! Unauthorised conversions and modifications to the product lead to considerable safety risks and are prohibited for safety reasons! Adamczewski elektronische Messtechnik GmbH is not liable for any damage resulting from this or for damage or for damage resulting from improper use.

Malfunctions that may impair safety must be eliminated immediately! The installer must make the manual available to the operator. The installer and the operator must have read and understood the manual before starting their work.

### Foreseeable misuse

In particular, this product must not be used in the following cases:

- In potentially explosive atmospheres. When operating in potentially explosive atmospheres, sparking may cause deflagration, fire or explosion.
- Use on humans and animals.

### Safe handling

This product complies with the state of the art and the recognised safety regulations. Each unit is tested for function and safety before delivery.

Only operate this product when it is in perfect condition, taking into account the manual, the usual regulations and guidelines as well as the applicable safety regulations and accident prevention regulations.

Extreme environmental conditions affect the function of the product.

- Protect product from shocks
- Use product indoors only
- Protect product from moisture

**Qualification of the staff**

Installation, commissioning, operation, maintenance, decommissioning and disposal may only be carried out by technically qualified personnel. Work on electrical parts may only be carried out by trained in accordance with the applicable regulations and directives.

**Changes to the product**

Unauthorised modifications to the product can lead to malfunctions and are prohibited for safety reasons.

**Use of spare parts and accessories**

The use of unsuitable spare parts and accessories can damage the product. Please use only original spare parts and accessories from the manufacturer.

**Disclaimer**

The manufacturer accepts no liability or warranty for damage or consequential damage resulting from failure to comply with the technical regulations, instructions and recommendations. The manufacturer is not liable for any costs or damage incurred by the user or third parties as a result of the use of this appliance, especially in the event of improper use, misuse or malfunctions of the connection, malfunctions of the appliance or connected devices.

# 3 Product description

The AD-VL 500 FE is a display, control unit and data logger for front panel installation. The device identifier **VL500-A8** identifies the device as an **A**nalogue data logger with **8** analogue input channels.

Measured values are displayed on a graphics-capable 3.5" TFT display. Numerical data can be displayed in tabular form on an HTTP page.

The AD-VL 500 FE is primarily used for the acquisition and logging of up to eight analogue measurement signals. It can still be connected via its RS-485 interface to one or more units of the Adamczewski elektronische Messtechnik GmbH or also to units of other manufacturers. Any data from these units can be displayed and/or logged to an internal SD memory card. The stored data can be transferred to a USB stick for further analysis at any time. The download of individual log files is also possible via the web interface.

The AD-VL 500 FE communicates with the connected devices (slaves) via the Modbus protocol and is the Modbus master.

The device can also be operated as a Modbus slave (with MB address 1...247) and data can be written to it.

## Features

- Display unit and data logger for front panel installation
- Buffered real time clock
- Display via graphics-capable TFT display
- RS-485 interface with Modbus RTU protocol (Master or Slave)
- USB connection for external data carriers
- PC interface or LAN interface for configuration or firmware update
- Creating your own displays with the Configuration software AD-Studio or web interface
- 8 analogue inputs for standard signals, current/voltage
- 8 counters (software, configurable, derived from the analogue inputs)
- Integrated linearisation formulas or table for tank contents
- Up to 10 configurable windows
- Up to 40 configurable display elements in total
- Up to 12 configurable display elements per window
- Up to 32 configurable logical signal channels.
- Display element types: Numeric, Bar, LED, Time Chart, Drag Pointer
- Configurable display element properties: position, size, labelling, colors
- Display element functions: Color change definable by hysteresis or window function
- Three operating languages: German, English, French
- Firmware update via network and USB data carrier

## Scope of supply

- AD-VL 500 FE
- All required pluggable terminals
- This instruction manual

The optional USB programming adapter **VarioPass** is required for configuration with the Configuration software AD-Studio .

## Order code

### AD-VL 500 FE

**VarioPass** Accessories: USB adapter for configuration with personal computer.

## 3.1 Block diagram

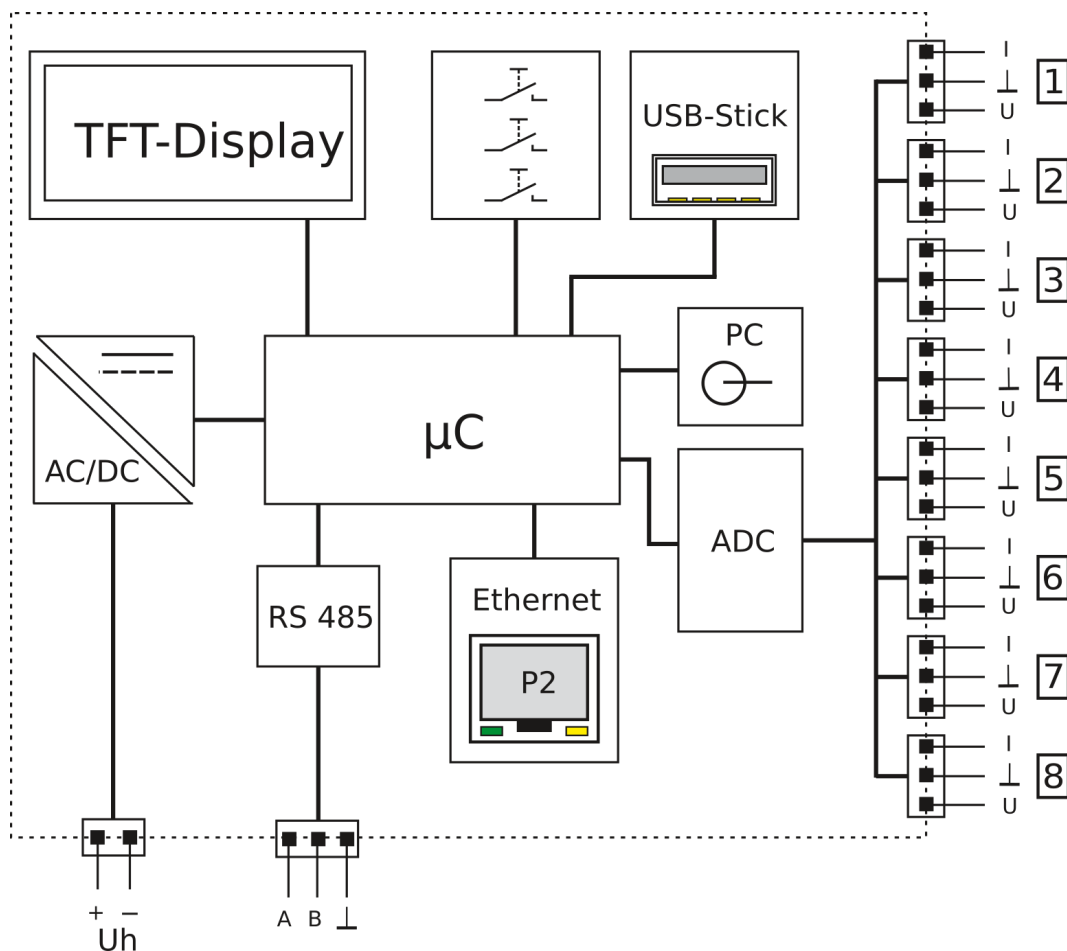

**Figure 3.1:** Block diagram of the AD-VL 500 FE

The connections 1...8 mark the analogue input terminals that are physically present.



## 3.2 Display and operating elements

The AD-VL 500 FE has a color graphics-capable TFT display for showing the data and three buttons for manual operation and configuration.

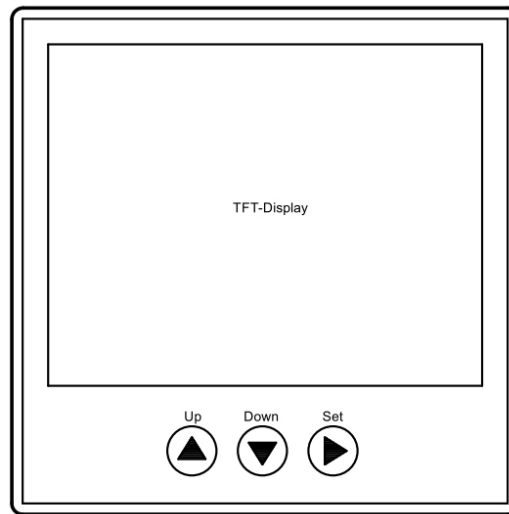

**Figure 3.2:** Display and operating elements of the AD-VL 500 FE

**Key 'Up'** Scroll up; increment digit

**Key 'Down'** Scroll down; decrement digit

**Key 'Set'** Confirm input

### 3.2.1 Status bars

In each display state, a header and footer bar with a grey background are shown in the display with status information.

The header bar contains the following status information, from left to right:

- Window number: [1]...[10]
- Window description: freely definable description text
- Date stamp: current date
- Time stamp: current time

The footer contains the following status information, from right to left:

- **LOG**, for data logger function
- **MB**, for Modbus communication
- **SD**, for internal memory card
- **USB**, for external storage medium (USB stick)
- **LAN**, for network status
- **DHCP**, for IP address reference
- **ADC**, is only displayed in the event of a hardware error, colored red
- **Function text** Autoscroll, Read/Write UART/RS485

The display within the footer follows a color scheme:

inactive = black, active = green, error = red, info text/data traffic = yellow

## 4 Technical data

### 4.1 Supply

Designation	Value
Supply voltage AC	50 ... 253 V
Supply voltage DC	20 ... 253 V
Max. Power consumption	3,0W / 9,5VA

### 4.2 Housing

Designation	Value
Dimensions (WxHxD)	96x96x63 mm
Panel cut-out	92x92 mm
Protection class front cover	IP 54
Protection class terminals	IP 20
Connection technology	removable screw terminals
Construction	panel housing
Weight	250 g

### 4.3 Environmental conditions

Designation	Value
Ambient temperature	-10 ... 50 °C
Storage and transport	-10 ... 70 °C (avoid condensation)
Degree of contamination	2

### 4.4 EMC

Designation	Value
Product family standard	EN 61326
Emitted interference	EN 55011, CISPR11 Class B

### 4.5 Electrical safety

Designation	Value
Product family standard	EN 61010-1

### 4.6 Analogue inputs

#### 4.6.1 Current inputs

Designation	Value
Range	0...20 mA
Resolution	14 bit
Input resistance	50 Ohm
Sampling rate	1/s
Damping	0...999 s

## 4.6.2 Voltage inputs

Designation	Value
Range	0...10 V
Resolution	14 bit
Input resistance	100 kOhm
Sampling rate	1/s
Damping	0...999 s

## 4.6.3 Counter

Designation	Value
Input signal range	0...20 mA; 0...10...24V
Switching thresholds	adjustable
Current input resistance	50 Ohm
Voltage input resistance	100 kOhm
Input frequency	maximal 1,5 Hz
Pulse width	minimum 300 ms
Pulse factor	0...10000
Pulse divider	1...100000
Range	0...9999999

## 4.7 Interfaces

### 4.7.1 RS485 interface

Designation	Value
Connector	3-pin socket 3.81mm pitch
Standard	RS-485
Function	Configuration, Modbus-Slave
Protocol	Modbus-RTU
Max. Number of participants	32
Max. Bus length	100 m
Bus termination	120 Ohm (both ends at bus end)

## 4.8 Configuration interface

Designation	Value
Connector	jack socket 3mm
Standard	UART, manufacturer specific
Function	Configuration

## 4.8.1 Network interface

Designation	Value
Connector	RJ45 socket
Standard	Ethernet, 10/100 Mbit/s
Addressing	IP4
DHCP	Factory activated
Protocol	TCP/IP (HTTP, Modbus-TCP)
Standard address	192.168.50.230
Configuration port	80
Modbus-TCP-Port	502
Function	Web server for configuration, file download and numerical data view

## 4.8.2 USB-Interface

Designation	Value
Connector	socket type A for USB stick
Standard	USB 1.0, 2.0
Formatting	FAT12, FAT16, FAT32
Function	Data transfer, configuration

## 4.9 Display

Designation	Value
Typ	3,5" TFT
Resolution	320x240 Pixel

## 4.10 Operation

Designation	Value
Type	3 short-travel keys
Network	via web browser

# 5 Assembly and commissioning

## Electrical connection



*The terminals of the auxiliary voltage inputs are dangerous to touch*

- Disconnect the mains voltage and secure it against reconnection.
- Ensure that the connections are protected against accidental contact.
- Protect all connections against electrostatic discharge.

## Commission the appliance

- Switch off the power supply.
- Check that there is no voltage.
- Mount the unit.
- Connect power supply and RS-485.
- Switch on power.
- Configure the unit. See chapter 7 for details.
- Check function.

# 6 Operation and menu navigation

## 6.1 Key functions

The menu is controlled by the three keys 'Up', 'Down' and 'Set', see chapter 3.2. The following abbreviations apply to the key functions:

**up** Key 'Up' press briefly

**UP** Key 'Up' press for longer than approx. 2s

**down** Key 'Down' press briefly

**DOWN** Key 'Down' press for longer than approx. 2s

**set** Key 'Set' press briefly

**SET** Key 'Set' press for longer than approx. 2s



*NO key combinations are used in the entire menu navigation (one-finger menu).*

## 6.2 Normal operation

After power on the unit, it is in the display state with the display of the last window shown. Press SET to enter the configuration menu. From the configuration menu, press SET to return to normal operation.

In normal operation, the pre-configured windows can be scrolled through with up or down or automatically.

In **normal mode**, among other things:

- Further display windows (windows 1...10) can be selected. The respective window number precedes the heading in square brackets.
- Settings are made on the AD-VL 500 FE .

Since the AD-VL 500 FE may access external Modbus slaves for data communication, a higher-level error monitoring of the master-slave data traffic takes place at the RS485 connection. If an error is detected, the green status information **MB** immediately changes to red. Possible errors are e.g.

- Timeout: The slave does not respond. Reasons can be an incorrect slave address, the slave is not connected or does not respond for another reason.
- Slave Exception: Reasons can be e.g. an incorrect number of data words or an incorrect or non-existent register.

This visual error message is not blocking. However, due to the time monitoring of the Modbus slaves, there may be time delays in measurement recording in the event of failures.

For diagnostic purposes, a short keystroke (set) can be used to display a log channel table showing all 32 log channels with the currently set up Modbus slave address and

register (**[channel] address/register**).

Detected communication errors are marked with a **E** after this indication. This view is automatically updated once per second. This table can only be activated in the event of an error.

## 6.3 Window navigation

The AD-VL 500 FE can display up to 10 display windows. Up to twelve display elements can be shown in one window. The current window number is shown in the display header, before the heading, in square brackets. (**[1] Headline**).

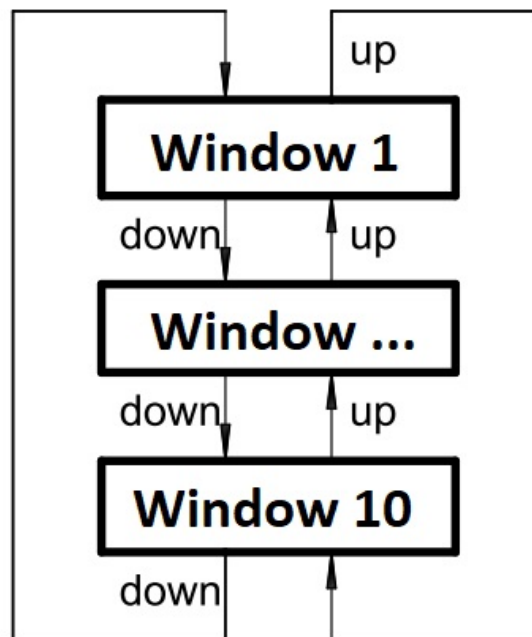

**Figure 6.1:** Scroll window

The windows can be opened, as shown in Fig. 6.1 can be scrolled up and down either manually with the 'Up' and 'Down' keys or automatically with a timer. A longer keystroke ('UP' or 'DOWN') in any direction initiates automatic, time-controlled switching to the next window. This state is shown in the footer with a yellow text **Autoscroll**. Switching back to manual mode is done in the same way.



*The time interval for the automatic scrolling function is set with the parameter ⇒ **Options** ⇒ **Autoscroll**.*

*The default time is 5 seconds.*

# 7 Configuration

The unit can be configured either directly on the unit, with the Configuration software AD-Studio (for Windows operating systems) or via the web interface. The Adamczewski elektronische Messtechnik GmbH provides prefabricated unit configurations, as XML files, are available.

The USB interface converter AD-VARIO-PASS is required for the PC/device connection with the Configuration software AD-Studio .

## 7.1 Analogue channel setup

Each of the eight analogue channels must be assigned the physical input signal (current or voltage). See chapter 7.2.2 on page 17.

The signal is connected to the corresponding terminals.

See chapter 9 on page 35.

Each analogue input can be scaled in its own range to display and log scaled quantities. The scaling does not yet contain a unit here. A scaling unit is set up directly on the log channel (1..32).

Each analogue input signal can be linearised with a linearisation function or a global linearisation table, by a function assignment **characteristic**. The linearisation table, with 24 interpolation points, contains the physical input variable (mA/V) as the input value and a numerical value as the output value.

See example in the web interface, chapter 10.10 on page 44.

The linearisation is done by interpolation between the interpolation points.

The linearisation of the different tank shapes, round tank (idealised) or spherical tank, is done according to a calculation formula.

The signal normalisation is realised by a multiplication of linearisation and scaling.

## 7.2 Configuration menu

In the configuration menu, various configuration items can be selected on the AD-VL 500 FE . If a configuration item requires a numerical index, the index selection is activated and queried. The index setting is made by means of a rolling number, which is set with the navigation keys. The numerical index is then shown in the menu heading in square brackets.

Example: **Configuration item [1]**.

### 7.2.1 Device information

Under **device-information**, various information on the status of the AD-VL 500 FE is displayed. Available memory sizes of the mounted data carriers are displayed here. A clear representation can also be found on the HTML status page (see chapter 10.7.1 on page 42).



## 7.2.2 Analogue inputs

Only the parameters of the analogue functions are set in this area.

The Analogue Inputs menu branch contains the following submenu branches:

- **Signal type** I / U
- **Characteristic** linear, round tank, spherical tank, table
- **Measuring range** Lower range value, upper range value
- **Scaling** Scaling start, scaling end
- **Filter** XXX s
- **Counter** Counter reading, switching threshold, pulse factor, pulse divider

The following parameters are available for configuring the analogue inputs.

Parametername	Default value	Range	Unit
Signal type	I	I / U	
Characteristic	linear	linear, round tank, spherical tank, table	
Measuring range	0...20	lower range value, upper range value	mA / V
Filter	0	0 ... 999	
Counter, counter value	0...9999999		
Counter, Switching threshold	5 / 9	Measuring range (0...20mA / 0...10V)	mA / V
Counter, Pulse factor	0...10000	0	
Counter, Pulse divider	1...100000	1	

The digital levels that control the counters are derived from the set-up counter switching thresholds. The corresponding logic values can be read on their own Modbus registers. See chapter 8.2 on page 33.

For level detection, an analog value must have safely reached the switching threshold and be stable for a minimum period of time (see chapter 4.6.3 on page 11) assume a stable state.

When using the voltage inputs as pulse inputs, voltage values up to 25 volts are permissible. However, they are only recorded analogue up to 10 volts.

A set filter leads **NOT** to an extension of this stabilization phase.

With pulse factor and pulse divider the incoming pulses can be evaluated (Count value = Input pulse x Pulse factor / Pulse divider).

The count values can only be saved automatically once per hour, in a non-volatile memory (EEPROM). All values accumulated within one hour are lost in the event of a supply voltage failure.



*Direct editing of the linearisation table on the AD-VL 500 FE is NOT provided. The table can be edited and transferred to the unit via the web interface or the Configuration software AD-Studio . Finished tables can be exchanged via the import and export functions using a USB stick.*

## 7.2.3 Windows

The Window menu branch contains the following submenu branches:

- **Display elements**
- **Show**
- **Labelling**
- **Index display element**

The following parameters are available for configuring the windows.

Parametername	Default value	Range	Unit
Number of display elements[N]	8	1 ... 12	
Show[N]	Yes	No, Yes	
Labelling[N]	'xyz...'	1 ... 30	
Index display element [N.1]		1 ... 40	
...			
Index display element [N.12]		1 ... 40	

With [N] as window number (1 ... 10).

The parameter **Number of display elements[N]** determines the number of display elements that are shown in this view. With the parameter **Show** determines whether the display is shown or not, this can be used to show or hide a parameterised display, e.g. temporarily or system-specifically. With **Index display element[N.1]** ... **Index display element[N.12]** the indices of the display elements to be shown are determined. Example: Index display element[2.5] = 3 means that the third display element is used as the fifth element of the second window.

## 7.2.4 Display elements

Up to 40 different display elements can be configured to show measured values within the display windows. A display element contains all the information for displaying a value from a logical log channel (1...32). It can be used in different windows, even multiple times.

The Display Elements menu branch contains the following submenu branches:

- **Show**
- **Scaling**
- **Color change**
- **Switching threshold**
- **Labelling**
- **top**
- **left**
- **Height**

- **Width**
- **Font size**
- **Orientation**
- **Standard color**
- **Alternative color**
- **Index** (Log channel number)
- **Interval** (for time diagram)

The parameters of the display elements differ greatly depending on the type of display and are explained below for the individual display types.

### Common parameters of all display elements

Most parameters apply to all display elements and are listed below.

Parametername	Default value	Range	Unit
Show[N]		Numeric 0, Numeric 1, Numeric 2, Numeric 3, Numeric 4, Numeric auto, Bar chart, LED, Time diagram, Drag indicator	
Color change function[N]		Off, Hysteresis, Window	
Switching points[N]	0 ... 1	float	'Unit'
Label position[N]	Left	Left, Right, Above, Below	
top[N]	10	5 ... 235	Pixel
left[N]	10	5 ... 315	Pixel
Height[N]	20	10 ... 220	Pixel
Width[N]	20	10 ... 300	Pixel
Standard color[N]	Green	Red, Green, Blue, Cyan, Magenta, Yellow, Orange, White, Black, Grey	
Alternate color[N]	Red	Red, Green, Blue, Cyan, Magenta, Yellow, Orange, White, Black, Grey	
Index channel[N]	1	1 ... 32	
Interval	1	1 ... 65535	s

[N] is the 1-based index of the display element [1...40].

With the parameter **Show[N]** the type of presentation can be selected.

The parameter **color change function[N]** determines whether and after which function the alternative color is used to represent the value from the channel.

The switching points define the limit values for the color change function.

They have the same unit as the value of the channel.

The parameter **Label position[N]** sets the position of the label relative to the display element.

The parameter **top[N]**, **left[N]**, **Height[N]**, **Width[N]** define the position and size of the display element within the representation area of the display.

The parameter **Standard color[N]**, **Alternate color[N]** the colors determine how the value is displayed.

The parameter **Index channel[N]** determines the channel to be displayed.

The parameter **Interval** is only used as a time grid for a set-up time diagram.



*The label and unit are automatically taken from the associated log channel.*

*The switching points and the alternative color are only evaluated if a color change function has been selected, i.e. 'Hysteresis' or 'Window'. The color change function is evaluated cyclically. If the return value is true, the display element uses the alternative color to represent the value.*

## Numerical display

In the numerical display, the value of the channel is shown together with the label and the unit.

The number of decimal places is set in the parameter **Numeric[N]** (0...4)

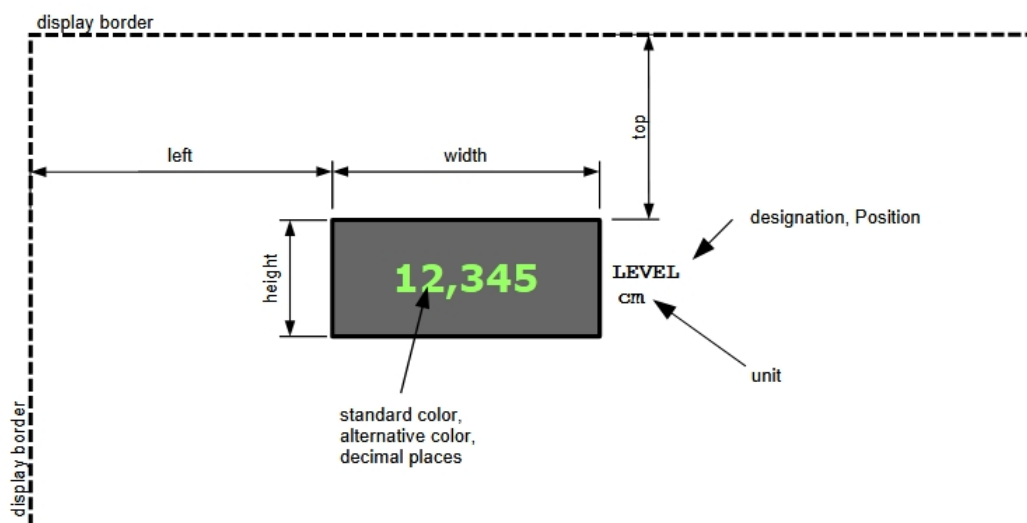

**Figure 7.1:** Representation as numerical display

The following parameters are additionally available for configuring the numerical display.

Parametername	Default value	Range	Unit
Font size	13x13	13x13, 19x16, 32x32, 35x45, 46x60	Pixel (BxH)

## Bar display

When displayed as a bar graph, the value of the channel is shown as a horizontal or vertical bar.

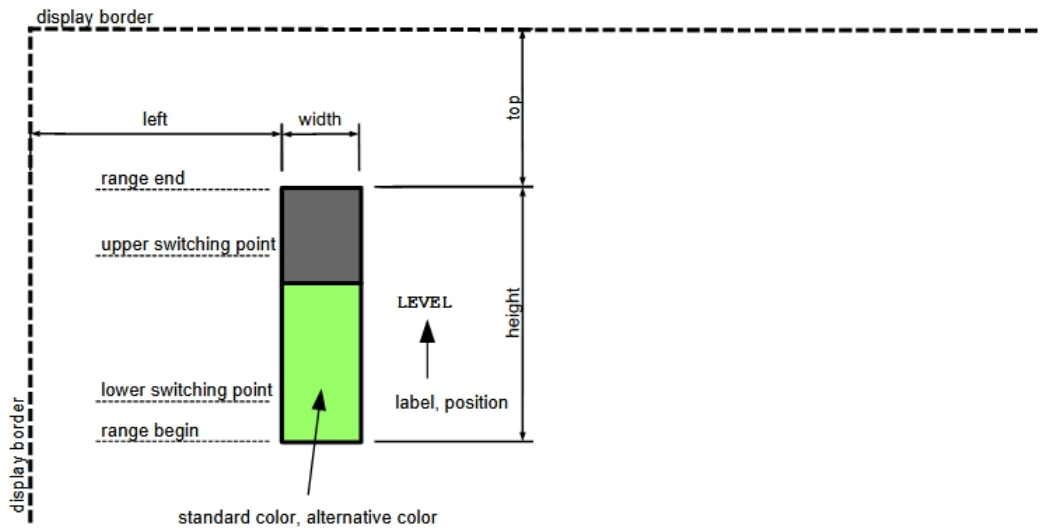

**Figure 7.2:** Display as bar chart

The following parameters are additionally available for configuring the display as a bar chart.

Parametername	Default value	Range	Unit
Scaling range	0 ... 1	float	
Orientation	Horizontal	Horizontal, Vertikal	

With the parameter **Scaling range** the physical value of the channel is scaled to the position and size of the bar within the display area.

With the parameter **Orientation** the orientation of the bar is set. With 'Horizontal' the bar runs from left to right, with 'Vertikal' the bar runs from bottom to top.

## LED display

In the LED display, the color of the active area of the LED changes from the standard color to the alternative color depending on the value of the channel and the color change function. The LED thus serves to indicate an activated operating state or two operating states.

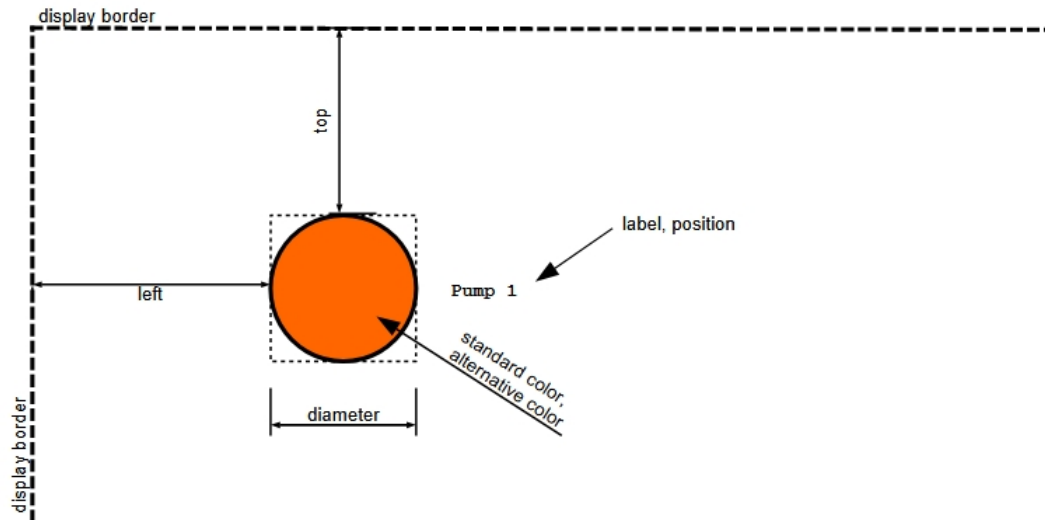

**Figure 7.3:** Display as LED



*In order for the LED to change color at all, one of the color change functions **MUST** be selected. If only an activated operating state is to be signalled, the standard color and alternative color can be selected accordingly, e.g. 'Green' = active, 'Grey' = not active. The diameter of the LED is specified in the parameter **width**.*

## Time diagram display

In the time graph display, the current value of the channel is plotted over the time axis in a defined period of time. After each sampling interval, a new value is calculated and plotted over the time axis. The time span that can be plotted over the time axis is calculated as follows

$$t_{\text{delta}}[\text{s}] = \text{WidthDisplayElement}[\text{Pixel}] * \text{SamplingInterval}[\text{s}/\text{Pixel}]$$

Example:

Width of the display element = 200 pixels, sampling interval of the channel = 5 s

$$t_{\text{delta}} = 200 * 5\text{s} = 1000\text{s}(16\text{min}, 40\text{s})$$

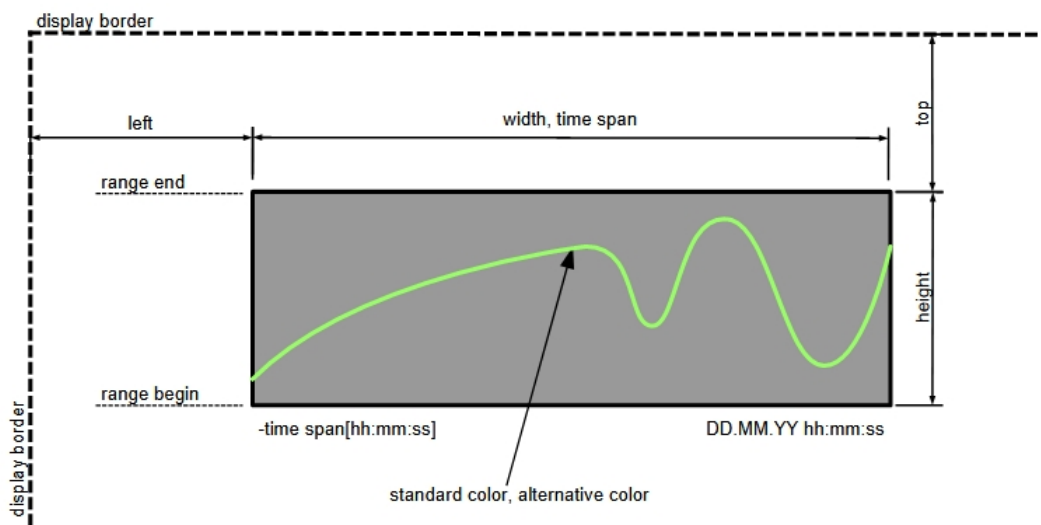

**Figure 7.4:** Representation as a time diagram

## Drag indicator

In the drag pointer display, the min and max value since the last reset of the drag pointer or the restart of the AD-VL 500 FE is displayed. The drag pointer can be reset via the main menu of the AD-VL 500 FE. The values for determining the min and max values are always determined automatically from all channels that are queried.

## 7.2.5 Log channels

There are 32 logical log channels available, which can be freely configured. These channels store all the parameters that the AD-VL 500 FE needs to record a value via the Modbus. The following parameters can be configured per channel:

Parametername	Default value	Range	Unit
Slave address[N]	1	0 ... 247	
Holding register[N]		0 ... 65535	
Data type[N]	FPN (Single)	U08, S08, U16, S16, U32, S32, FPN	
Log interval[N]	5	1 ... 65535	s
Log enable[N]	off	off, on	
Label[N]	'Kanal N'	0 ... 20	char
Unit[N]	'?'	0 ... 10	char

[N] is the 1-based index of the channel [1..32].

Example: With the setting **Slave address** = '2', **Holding register** = '41120', **Data type** = 'FPN(Single)', **Log interval** = '10', a floating point number from the modbus slave with slave address 2 is stored in the log file every 10 seconds.



*Choose a log interval that is as large as possible to keep file sizes down. Large files have an unfavourable effect on time, data transfer and later evaluation.*

Basically, all holding registers that have an entry greater than zero are read permanently. This means that these values can be shown on the display or the HTML page without necessarily having to be logged.

Activation of the log function of the individual holding register itself is done with the selector switch **log enable = on**.



*Floating point numbers (single or float) according to IEEE 754 have a size of 4 bytes, so 2 Modbus registers are read.*

The AD-VL 500 FE only contains default values as analogue data logger. When connecting additional Modbus slaves, the AD-VL 500 FE must always be set up for the application. This can be done by the user himself or in consultation with the Adamczewski elektronische Messtechnik GmbH. Ready-made configurations can be downloaded from the manufacturer's website.



*The unit's own data (measured values, counter readings) are read on the virtual slave address 0 and are not communicated via the physical RS-485 interface.*



## 7.2.6 Log settings

Whether to log is determined once per second (see picture 7.5). It can be logged permanently without condition or depending on a certain condition. Conditional logging can be controlled by a limit value, a trend or by a time condition. In addition, the availability of the hardware is checked. The Log Settings menu branch contains the following submenu branches:

- **Log enable**
- **Log mode**
- **Channel index**
- **Switching threshold**
- **Trend delta**
- **Trend timespan**
- **once**
- **daily**
- **Start time**

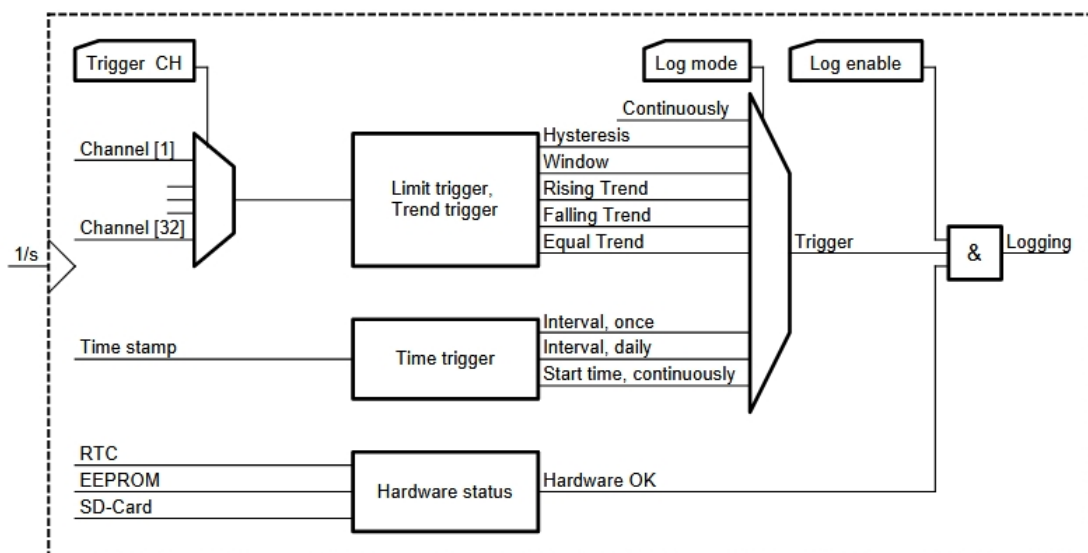

**Figure 7.5:** Determination of the log release of the AD-VL 500 FE

The following parameters are provided to control logging:

Parametername	Default value	Range	Unit
Log enable	off	off, on	
Log mode	Continuously	Continuously, Hysteresis, Window, Rising Trend, Falling Trend, Equal Trend, Interval once, Interval daily, Start time continu- ously	

Parametername	Default value	Range	Unit
Channel index	1	1 ... 32	
Switching threshold	0,0...1,0	float-Range	Trigger channel
Trend delta	1,0	1E-6...1E6	Trigger channel
Trend timespan	10	1...3600	s
Start time once	11.11.2018 11:11:11		
End time once	11.11.2018 11:11:12		
Start time daily	11.11.2018 11:11:11		
End time daily	11.11.2018 11:11:12		
Start time continuously	11.11.2018 11:11:12		



To quickly start and stop the log process, use the global parameter **Log enable**

### Log permanently

If logging is to be continuous and without condition, the following parameters must be set.

1. **Log mode** = *'Continuously'*
2. **Log enable** = *'on'*

The trigger conditions for limit value, trend and time are not observed. The log process starts immediately and ends only when **Log enable** = *'off'* is set or another log mode is selected.

### Hysteresis-triggered logging

If the trigger condition is to be effected by a hysteresis function, the following parameters must be set.

1. **Log mode** = *'Hysteresis'*
2. **Trigger channel** = *'1...32'*. Channel number for determining the value
3. **Switching threshold** = *'lower limit value, upper limit value'*
4. **Log enable** = *'on'*

The hysteresis function is activated when the value of the trigger channel exceeds the upper limit value. It is deactivated when the value falls below the lower limit.

### Window-triggered logging

If the trigger condition is to be carried out by a window function, the following parameters must be set.

1. **Log mode** = *'Window'*
2. **Trigger channel** = *'1...32'*. Channel number for determining the value

3. **Switching threshold** = '*lower limit value, upper limit value*'.
4. **Log enable** = '*on*'

The window function is activated when the value of the trigger channel is within the limit values. It is deactivated when it is outside the limits.

### Trend-triggered logging

If the trigger condition is to be carried out by a trend function, the following parameters must be set.

1. **Log mode** = '*Trend rising, trend falling or trend the same*'
2. **Trigger channel** = '*1...32*'. Channel number for determining the value
3. **Trend delta** = '*Difference*'. Signal difference above which a trend is detected.
4. **Trend time** = '*Time interval*'. Time span between measurements.
5. **Log enable** = '*on*'

### Time-triggered logging

Time-triggered logging can be **once**, **daily**, or **from a certain time**.

If **once** is to be logged at a certain time interval, the following parameters must be set.

1. **Log mode** = '*Interval once*'
2. **Start time once** = '*DD.MM.YYYY hh.mm.ss*'. Start date and time
3. **End time once** = '*DD.MM.YYYY hh.mm.ss*'. End date and time
4. **Log enable** = '*on*'

It is logged if the current time is between **start time once** and **end time once**.

If **daily** is to be logged at a certain time interval, the following parameters must be set.

1. **Log mode** = '*Intervall daily*'
2. **Start time daily** = '*DD.MM.YYYY hh.mm.ss*'. Start time of the log operation.
3. **End time daily** = '*DD.MM.YYYY hh.mm.ss*'. End time of the log operation.
4. **Log enable** = '*on*'

It is logged if the current time is between **start time daily** and **end time daily**.



*The date in the parameters **start time daily** and **end time daily** is ignored because only the time is necessary to determine the daily log interval. Therefore, any date can be entered.*

If **from a certain time** is to be logged, the following parameters must be set.

1. **Log mode** = '*Start time continuously*'
2. **Start time continuously** = '*DD.MM.YYYY hh.mm.ss*'. Start date and time
3. **Log enable** = '*on*'

It is logged if the current time is after the start time.

## 7.2.7 Options

In the menu **Options** the following settings can be made:

- **User** Here you can choose between 'Admin' and 'Standard'. Depending on the user setting, certain data and functions of the AD-VL 500 FE are not accessible or only accessible to a limited extent.
- **Language** The menu language for the AD-VL 500 FE can be selected here.
- **Brightness** Here you can set the brightness of the TFT backlight in %.
- **Color scheme** An alternative display representation (dark/bright) can be selected here.
- **Autoscroll** Here you can change the time grid for the automatic scrolling function.
- **Drag indicator** All drag pointers can be reset here. Note: A drag indicator runs in the background for each channel, regardless of whether it is displayed or not.
- **Date** Here you can set the date and time of the real-time clock for the log function.
- **Factory values** The unit is reset to the factory settings. The unit is then restarted automatically. For safety reasons, counter values are not deleted.
- **Device reset?** This can be used to trigger a unit restart without interrupting the supply voltage.

## 7.2.8 Network

- **Clear LAN password** This enables a new user/password assignment on the web interface.
- **IP address** Here you can assign your own IP address.
- **Subnet** Setting an IP network mask with fixed IP address assignment.
- **DHCP** Activation or deactivation for automatic IP address retrieval from a DHCP server.

## 7.2.9 RS485

This is where the configuration of the RS485 interface is adapted to the bus system to be connected. The Modbus protocol used by the AD-VL 500 FE always works with 8 data bits and one stop bit.

- **Address**  
Setting of own address 1...247 in slave mode.  
At 0, the Modbus master mode is activated and the AD-VL 500 FE can log external device data.  
The virtual registers can be written to in slave mode.  
The device works as a display device.
- **Baud**  
Selection of the required baud rate from a list of usable values.
- **Parity**  
Selection of a required parity from a list (even/odd/none).

## 7.2.10 Delete files

All day files (\*.csv) can be deleted from the internal memory card here. The current, locked day file and the device-specific information file (\*.LOG) are not deleted for security reasons.

## 7.2.11 Configuration

- **export** With this, the current configuration settings (VL500-A8.CFG) and the linearisation table (VL500-A8.LIN) can be saved as a file on a USB stick. Existing files are **always overwritten** without confirmation!
- **import** This allows previously saved configuration settings or a linearisation table to be transferred to the unit. Both files are imported one after the other. In this process, it is sufficient that only one of these files is present. If no file by name is available, an error message **File ERROR** is displayed (red in color).



*The menu item **Configuration** only appears in the menu if a USB stick has also been inserted and recognised by the AD-VL 500 FE .*

The files can also be accessed via the web interface (chapter 10.7.8, page 49) transferred.

However, they are **NOT** compatible with the Configuration software AD-Studio .

The AD-VL 500 FE checks the files for compatibility. They must not be manipulated. Incorrect import files are answered with a message **File ERROR**.

## 7.2.12 Backup to USB

Under **Backup to USB**, the contents of the internal SD memory card can be transferred to an USB stick inserted in the back of the unit.

Only new files that do not exist by name are transferred.

Existing files with the same name are not overwritten.

The data carrier can be easily removed after the data transfer.

The file copying process of large or many files can take up a lot of time. This delays other functions of the unit.



*The menu item **Backup to USB** only appears in the menu if a USB stick has also been inserted and recognised by the AD-VL 500 FE .*

# 8 Modbus

## 8.1 Basics

The AD-VL 500 FE works as a modbus slave on its RS-485 interface at the factory. The operating mode as modbus master must be set up specifically.

Detailed descriptions of the modbus protocol are available at the following link:

<http://www.modbus.org> or also on the manufacturer's website:

[https://www.adamczewski.com/media/modbus\\_application\\_protocol\\_v1\\_1b3.pdf](https://www.adamczewski.com/media/modbus_application_protocol_v1_1b3.pdf)

### RS-485 Interface parameters

The RS-485 interface works with the following settings as standard.

The possibility to change these parameters is only required in exceptional cases and is not necessary when using Adamczewski elektronische Messtechnik GmbH devices.

Name	Value
Baud	19200
Data bits	8
Parity	even
Stop bits	1

### Data types

The following data types are used:

Typ	Size	Number of words
bool	1 Byte	1
u16	2 Byte	1
u32	4 Byte	2
single(IEEE 754)	4 Byte	2

According to the modbus specification, words are transmitted with two bytes as the smallest unit in 'big-endian' format. All information is therefore multiples of one word. An exception is the checksum. It is transmitted in the format 'little-endian' (least significant byte first) is sent.

## Modbus functions used

The AD-VL 500 FE uses only the function to communicate with the slaves:

### 3 (0x03) Read Holding Registers.

The following abbreviations are used when explaining the telegrams:

**SA** Slaveaddress

**FC** Functioncode

**RH** Register Highbyte

**RL** Register Lowbyte

**RCH** Registercount Highbyte

**RCL** Registercount Lowbyte

**BC** Bytecount

**D0H** Dataword 0 Highbyte

**D0L** Dataword 0 Lowbyte

**DNH** Dataword n Highbyte

**DNL** Dataword n Lowbyte

**CRCL** 16-Bit CRC Lowbyte

**CRCH** 16-Bit CRC Highbyte

## Read Holding Registers

This function is used to read one or more registers.

Example: The master sends a request with the start address 40801 (0x9F61) and a number of registers to be read of 2 (0x0002) to the slave. If everything is OK, the slave responds with the number of bytes and the requested registers.

### Request

SA	FC	RH	RL	RCH	RCL	CRCL	CRCH
1	0x03	0x9F	0x61	0x00	0x02	...	...

### Response

SA	FC	BC	D0H, D0L, DNH, DNL	CRCL	CRCH
1	0x03	4	0x00, 0x00, 0x00, 0x00	...	...

In case of an error, the slave responds with an error message:

### Exception

Slave	Error code	Exception	CRC Low	CRC High
1	0x83	see 8.1		

## Write Multiple Registers

This function is used to write one or more registers, but is only supported by the AD-VL 500 FE for single parameters.

The master sends a request with the start address, the number of registers and the registers to be written to the slave. If all data is in order, the slave answers with the start address and the number of written registers.

Example: the master writes a 4-byte counter (unsigned uint32) with the value 243186 (0x0003B5F2) to register 45300 (0xB0F4) of the slave with address 2.

### Request

SA	FC	RH	RL	RCH	RCL	BC	D0H, D0L, ... DNH, DNL	CRCL	CRCH
2	0x10	0xB0	0xF4	0x00	0x02	0x04	0x00, 0x03, 0xB5, 0xF2	...	...

### Response

Slave	Funk.	reg. High	reg. Low	Anzahl High	Anzahl Low	CRC Low	CRC High
1	0x10	...	...	...	...	...	...

If an error occurs, the AD-VL 500 FE responds with an error message:

### Exception

Slave	Error code	Exception	CRC Low	CRC High
1	0x90	see 8.1	...	...

## Exception Codes

In the event of an incorrect request, the slave responds with an error telegram and one of the following exception codes. The function code with 0x80 is returned as the error code.

**1 (0x01)** The modbus function is not supported.

**2 (0x02)** The register address does not exist.

**3 (0x03)** The data are invalid.



## 8.2 AD-VL 500 FE Data register

This data can be read out via the serial interfaces or modbus TCP.

### 8.2.1 Local Modbus register

The AD-VL 500 FE provides its own data derived from the analogue inputs via the modbus protocol. This data is required when setting up the log channels (1...32). See chapter 7.2.5 on page 24.

In the delivery state or when restoring the factory setting of the AD-VL 500 FE, the log channels are already set up correctly.

Register	Number of registers	Name	Unit	Data type	read	write
40019	2	Analogue input 1	mA/V	float	yes	no
40019	2	Analogue input 2	mA/V	float	yes	no
40021	2	Analogue input 3	mA/V	float	yes	no
40023	2	Analogue input 4	mA/V	float	yes	no
40025	2	Analogue input 5	mA/V	float	yes	no
40027	2	Analogue input 6	mA/V	float	yes	no
40029	2	Analogue input 7	mA/V	float	yes	no
40031	2	Analogue input 8	mA/V	float	yes	no
40033	2	Scaling value 1		float	yes	no
40035	2	Scaling value 2		float	yes	no
40037	2	Scaling value 3		float	yes	no
40039	2	Scaling value 4		float	yes	no
40041	2	Scaling value 5		float	yes	no
40043	2	Scaling value 6		float	yes	no
40045	2	Scaling value 7		float	yes	no
40047	2	Scaling value 8		float	yes	no
40051	1	Digital level 1	0/1	U16	yes	no
40052	1	Digital level 2	0/1	U16	yes	no
40053	1	Digital level 3	0/1	U16	yes	no
40054	1	Digital level 4	0/1	U16	yes	no
40055	1	Digital level 5	0/1	U16	yes	no
40056	1	Digital level 6	0/1	U16	yes	no
40057	1	Digital level 7	0/1	U16	yes	no
40058	1	Digital level 8	0/1	U16	yes	no
40061	2	Counter 1		U32	yes	yes
40063	2	Counter 2		U32	yes	yes
40065	2	Counter 3		U32	yes	yes
40067	2	Counter 4		U32	yes	yes
40069	2	Counter 5		U32	yes	yes
40071	2	Counter 6		U32	yes	yes
40073	2	Counter 7		U32	yes	yes
40075	2	Counter 8		U32	yes	yes

### Diagnostic help

The Configuration software AD-Studio can read out the data of the table in real time and, if necessary, also log it. They are also displayed on the web server start page.

## 8.2.2 Modbus virtual registers

In addition, the data of the log channels (1...32), which were read internally or externally in modbus master mode at the RS-485 interface, can be read via virtual data registers using modbus TCP.

These registers can be written to at any time.

However, the values are updated as soon as the device itself (as Modbus master) can determine new data via the RS-485 interface.

Modbus slave mode can be used to prevent external data from being updated can be prevented.

Internal device data is always updated by the device itself (see chapter 8.2 on page 33).

Three groups of data types with 32 channels each are available, whereby an automatic assignment of the source data type to one of the three possible data types, depending on the sign, takes place.

Register	Number of registers	Log channel	Data type	Log channel data type
45001	2	Virtuell 1	U32	U08, U16, U32
...	2	...	U32	U08, U16, U32
45032	2	Virtuell 32	U32	U08, U16, U32
45101	2	Virtuell 1	S32	S08, S16, S32
...	2	...	S32	S08, S16, S32
45132	2	Virtuell 32	S32	S08, S16, S32
45201	2	Virtuell 1	float	float
...	2	...	float	float
45232	2	Virtuell 32	float	float

The last two digits of a register correspond to the index of the associated log channel (1...32).

# 9 Wiring diagram

## Pin assignment

Connection, Pin	Function
Uh, L/24V	Supply, polarity independent
Uh, N/0V	Supply, polarity independent
Ethernet	LAN connection
RS-485, A	RS-485 line A
RS-485, B	RS-485 line B
RS-485, GND	RS-485 ground/shield
AD-PC	3,5 mm Jack socket for VarioPass
USB	USB socket type A for USB stick
IN 1...IN 8	Analogue input sockets (Grid 3,81mm) for current (I) resp. voltage (U) with +polarity against ground

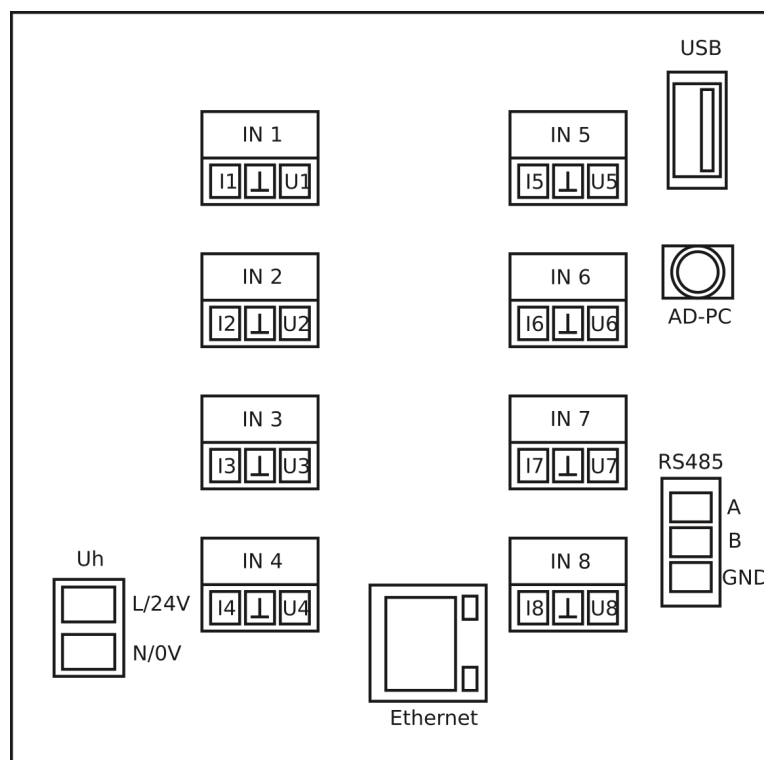

**Figure 9.1:** Pin assignment of the AD-VL 500 FE . Rear view of the unit.

## RS-485

The figure 9.2 shows the configuration of the RS-485 interface with several subscribers in a Modbus segment according to the specification 'Modbus over serial line'.

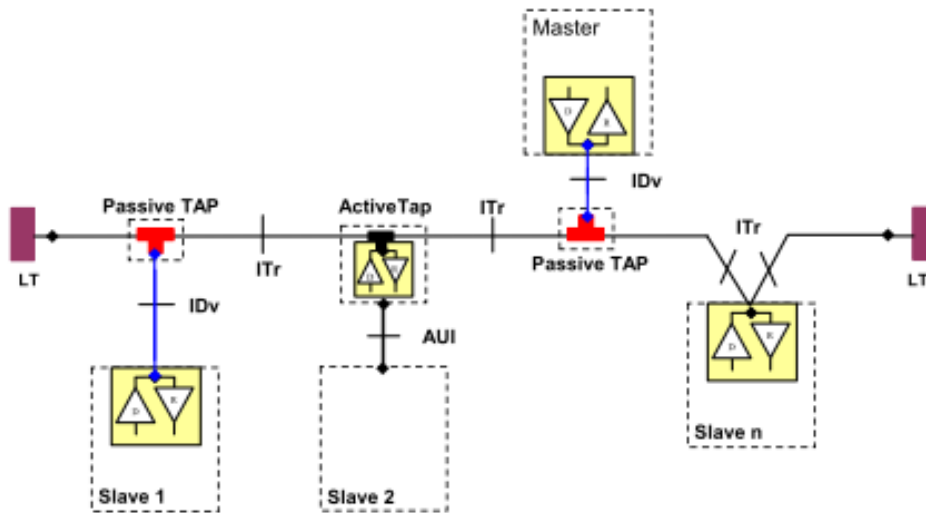

**Figure 9.2:** RS-485 with several bus participants

**ITr** Twisted, shielded cable must be used as bus cable

**IDv** Passive stubs must be as short as possible

**Mass** The earth connection of all bus participants must be connected to each other

**LT** The bus line must be terminated at both ends with 120 Ohm terminating resistors between lines A and B.

# 10 Network connection

Setting up network devices can require extensive knowledge. If you are unsure or have any questions, please contact your network administrator.

The Adamczewski elektronische Messtechnik GmbH cannot give any information about your local network, but only about the AD-VL 500 FE itself.

## 10.1 Connection

The connection to a LAN (Local Area Network) is made on the back of the unit. See chapter 9 on page 35.

By factory default, the AD-VL 500 FE obtains its IP address settings from an IP address stored in the

DHCP server present in the network.

The active DHCP setting can be seen in the display footer of the AD-VL 500 FE (DHCP in green letters).

An active network connection can be seen in the display footer of the AD-VL 500 FE (LAN in green letters). During network communication, the font color is temporarily changed to yellow.

Information of the active network connection (IP address, etc.) can be viewed on the unit under **unit information**.

If direct access to the unit is not possible, unknown unit addresses of units in the Adamczewski elektronische Messtechnik GmbH can also be determined with the help of the auxiliary programme **Find NETWORK-DEVICE** (see chapter 10.8, page 51).

## 10.2 Protocols

The integrated HTTP web server is accessed on the standard port 80.

The Modbus TCP connection is possible on port 502, e.g. to read out measured values automatically. A maximum of 28 registers (56 data bytes) can be read simultaneously in one block.

This connection can also be used to read data from channels that have not been set up for logging or display on the unit.

To read data via a Modbus TCP connection, a so-called Modbus TCP master is required. This requires special expertise. Contact an external service provider if you cannot operate such systems yourself.

For simple operation of the AD-VL 500 FE, with local analogue signals, such a connection is not required.

## 10.3 Data security

The operator is responsible for data security in the network.  
If access from public networks is desired, this should be done via a VPN tunnel.

The network-side device access via the Modbus TCP connection is unprotected, as it is an open protocol. Data can be read and configuration data can also be written via this connection.

The data required for the operator are listed in a table, in chapter 8.2 on page 33, aufgeföhrt.

The integrated HTTP web server contains password protection that prevents unauthorised configuration changes. See chapter 10.2 on page 40.

Access data entered incorrectly several times will be answered with a page content **wrong password**.

Lost access data can only be reset directly at the AD-VL 500 FE (⇒ **Network** ⇒ **Clear LAN Password**).

The HTML start page (chapter 10.1 on page 39) with the set-up measurement data can be called up at any time without security queries. This is data that is usually intended to be immediately, visually available on one's own network.

The current firmware of the AD-VL 500 FE behaves passively and does not make any independent or uncontrolled connections to other devices or servers via the LAN connection. connection to other devices or servers.

## 10.4 Navigation

The internal HTML pages are mainly structured numerically. Calling up unknown HTML pages is answered with an error page: **Page xxx not available**.

HTML page navigation using a web browser should therefore be carried out exclusively by clicking on the corresponding links. This ensures smooth operation. The page numbers of the internal web server can also change after a firmware update.

If there are input fields on an HTML page, the data contained therein is transferred to the AD-VL 500 FE by clicking on the field **save**.

An HTML link **back** always leads to the parent HTML page.

The character width of the input fields is partly limited, so that field contents must first be deleted before new characters can be entered.

Numeric input fields are locked for letter entries.

Some of these input fields have a mouseover function. Here, input limits are displayed as help text.

## 10.5 Homepage

The start page shows the instantaneous values of all log channels (max. 32) in tabular form, provided they have been activated with a Modbus register address (greater than zero) or with a log enable.

Each HTML page contains the company logo, the unit designation and the unit serial number.

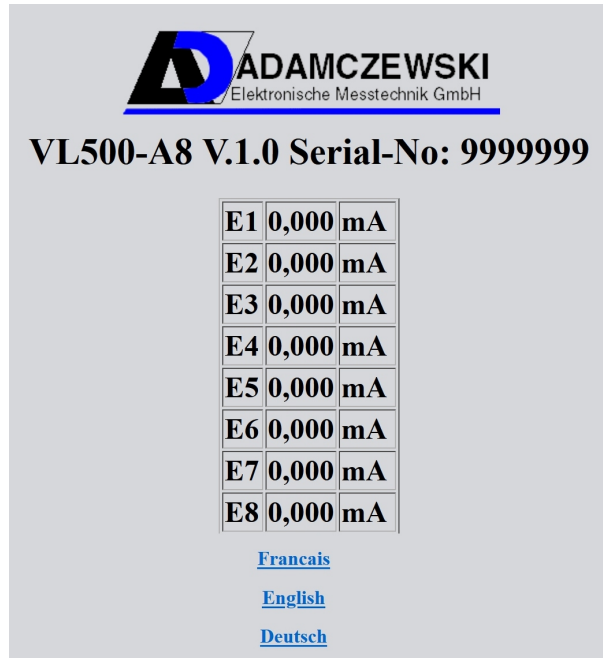

**Figure 10.1:** Home page with measured values

Below the table, three further language links have been set up that lead to the configuration pages in the specified user language.

A table line contains the plain text channel designation, the numerical value and the unit of measurement entered at the log channel.

As soon as the global log release is made, an additional column is added to the table showing the individual log specifications.

A **L** indicates that this channel is included in the log file.

An empty table field shows that the log release of this log channel has been deselected and the measured value is therefore only displayed visually on the HTML start page or on the unit.

The table values, which are exclusively numerical, are updated every second.

If a number field does not contain any data, this state indicates a communication failure or incorrect parameter settings on the associated log channel.

Changes to the log channel settings are only updated automatically every 255 seconds by a complete page load.

However, this page update can be triggered manually at any time.

## 10.6 Configuration

When one of the configuration pages is accessed for the first time, an access check is carried out with a request for user name and password. If no access data has been assigned yet, both fields can be freely filled. Otherwise the default user name is **admin** and the password field remains empty. This data can be reset directly on the unit or the web interface.

The access data is temporarily stored in the web browser until it is completely closed.

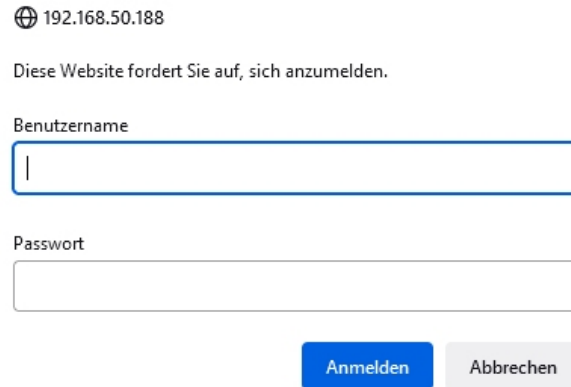

192.168.50.188

Diese Website fordert Sie auf, sich anzumelden.

Benutzername

Passwort

Anmelden Abbrechen

**Figure 10.2:** Access check



*If the access data is no longer available, a manual deletion of the LAN password directly on the AD-VL 500 FE (see chapter 7.2.8, page 28) mandatory. This ensures that only the owners of the AD-VL 500 FE who have physical access can release network access.*



## 10.7 Configuration pages

On the first main overview page, separate configuration parameters can be specifically selected.

- **Device information**
- **Analogue inputs**
- **Windows**
- **Display elements**
- **Log channels**
- **Log settings**
- **Options**
- **Configuration**
- **Network**
- **RS485**
- **back**

An HTML link **back** always leads to the parent HTML page.

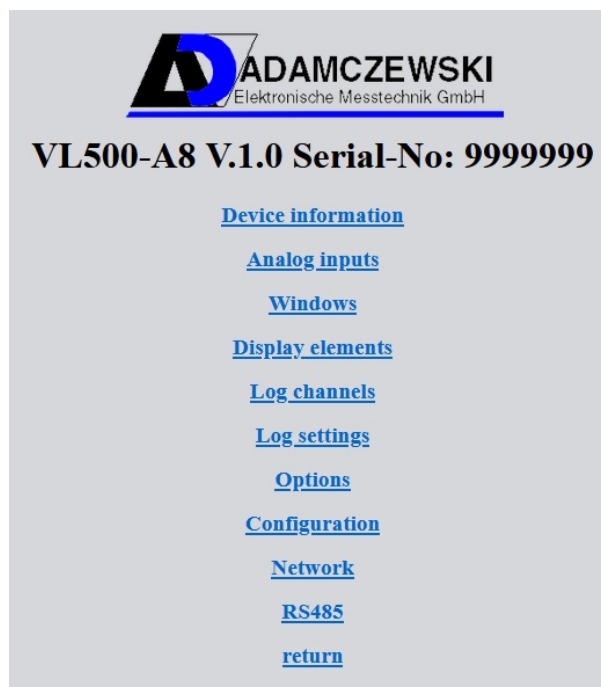

**Figure 10.3:** Configuration start page

## 10.7.1 Device information

The unit information provides a status overview. Here you can see important system information that is also requested in the event of manufacturer queries.

A clear presentation can also be found in the device menu (see chapter 7.2.1 on page 16).

The storage contents of the mounted data carriers can be accessed via the links.

<b>OEM</b>	Adamczewski
<b>Power off</b>	18.06.2023 12:46
<b>New start</b>	18.06.2023 13:19:37
<b>RTC</b>	18.06.2023 13:20:16
<b>Gerät</b>	VL500-A8
<a href="#">Firmware</a>	V.1.2
<b>Parameterversion</b>	P.1.0
<b>Firmwaredatum</b>	Jul 12 2023 09:52:46
<b>Serien-Nr:</b>	1643500
<b>ADC-8</b>	OK
<b>MB-Error</b>	0
<b>MAC-Adresse</b>	8C:1F:64:F4:E1:69
<b>DHCP</b>	ein
<b>IP-Adresse</b>	192.168.50.106
<b>Subnetz</b>	255.255.255.0
<b>Gateway</b>	192.168.50.99
<a href="#">SD Card</a>	OK SD, SD_3.0; 1966080 / 1968736 kB (99%)

**Figure 10.4:** Device information

Click on the links to download the files.

SD Card			
<a href="#">20230215.CSV</a>	<a href="#">9999999.LOG</a>	<a href="#">20230221.CSV</a>	<a href="#">20230302.CSV</a>
<a href="#">20230315.CSV</a>	<a href="#">20230316.CSV</a>	<a href="#">20230317.CSV</a>	<a href="#">20230320.CSV</a>
	<a href="#">20230404.CSV</a>		
	<a href="#">return</a>		

**Figure 10.5:** Memory content of the SD card

USB Memory			
<a href="#">20230215.CSV</a>	<a href="#">9999999.LOG</a>	<a href="#">20230221.CSV</a>	<a href="#">20230302.CSV</a>
	<a href="#">20230315.CSV</a>		
	<a href="#">return</a>		

**Figure 10.6:** Memory content USB stick

## 10.7.2 Analogue inputs

Here you can find the further links to the analogue input configuration.  
A link leads to the respective desired analogue channel configuration (page 44).

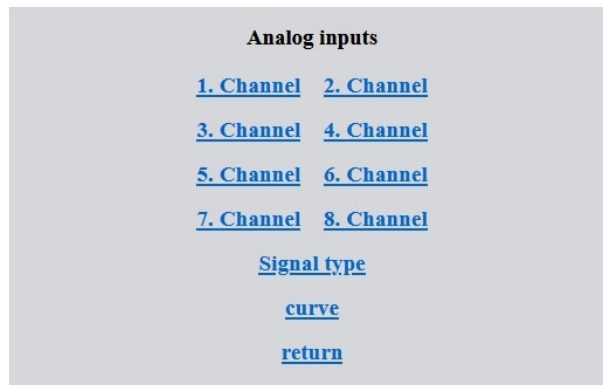

**Figure 10.7:** Analogue input configuration

Before setting up the parameters, the physical analogue inputs (current/voltage) can be defined here under **Signal type**, with the corresponding symbols **I** or **U**.

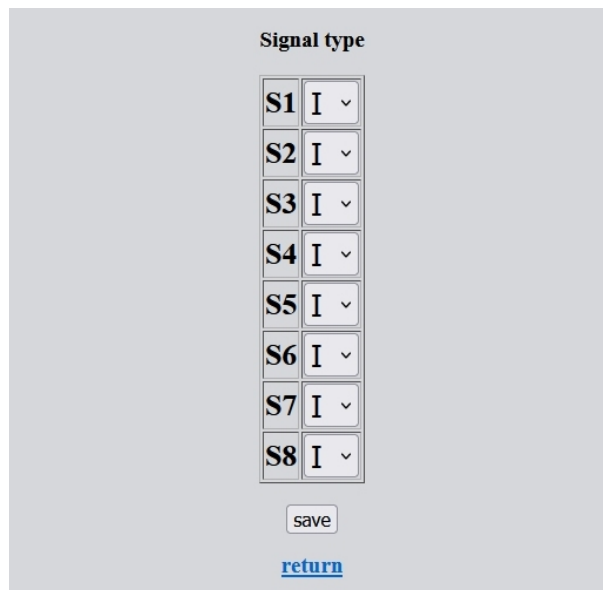

**Figure 10.8:** Signal type configuration Analogue input 1..8

Example illustration for setting up the first analogue input.

**Analog in 1**

<b>curve</b>	linear	▼
<b>Measuring range Start</b>	0,000	mA
<b>Measuring range End</b>	20,000	mA
<b>Scaling Start</b>	0,000	
<b>Scaling End</b>	100,000	
<b>Filter</b>	0	s
<b>Counter reading</b>	0	
<b>Switching threshold off</b>	1,200	mA
<b>Switching threshold on</b>	2,100	mA
<b>Pulse factor</b>	1	
<b>Pulse divider</b>	1	

[return](#)

**Figure 10.9:** Analogue input configuration 1...8

A linearisation table is provided in the AD-VL 500 FE that can be used by each individual analogue channel (1...8). The assignment is made directly at the analogue channel configuration with the parameter **characteristic** (see chapter 10.9, on page 44).

**curve**

mA / V	
0,000	0,000
0,000	0,000
1,000	0,050
2,000	0,100
3,000	0,150
4,000	0,200
5,000	0,250

**Figure 10.10:** Characteristics table with 24 value pairs

The function is described in chapter 7.1 on page 16.

### 10.7.3 Configuration windows

Up to twelve display elements (1...40) can be assigned to each of the ten available windows.

The number of **display elements** to be displayed is also determined here.

The desired window caption is entered in the **caption** field.

With **Display yes/no** a window can be easily selected and deselected.

Window 1	
Display elements	8
Show	Yes ▾
Labeling	Signale E1-E8
Index display element 1	1
Index display element 2	2
Index display element 3	3
Index display element 4	4
Index display element 5	5
Index display element 6	6
Index display element 7	7
Index display element 8	8
Index display element 9	1
Index display element 10	1
Index display element 11	1
Index display element 12	1

[return](#)

Figure 10.11: Configuration window

For an extended description see chapter 7.2.3 on page 18.

### 10.7.4 Display elements

This page is used to select the configuration of the individual display elements (1...40).

**Display elements**

[1. Display element](#)   [2. Display element](#)  
[3. Display element](#)   [4. Display element](#)  
[5. Display element](#)   [6. Display element](#)  
[7. Display element](#)   [8. Display element](#)  
[9. Display element](#)   [10. Display element](#)

Figure 10.12: Display elements

The parameters of a display element that can be set here are described in chapter 7.2.4 on page 18.

Display element 1	
Show	Bargraph ▾
Scaling Start	0,000 %
Scaling End	100,000 %
Colour change	Hysteresis ▾
Switching threshold off	90,000 %
Switching threshold on	95,000 %
Label position	Above ▾
top	40
left	10
Height	165
Width	25
Font size	32x32 ▾
Orientation	Vertical ▾
Standard colour	Cyan ▾
Alternate color	Red ▾
Log channel	9
Interval	1 s

[save](#)  
[return](#)

**Figure 10.13:** Example: Display element 1

## 10.7.5 Log channels

This page is used to select the individual channel configurations (1...32).

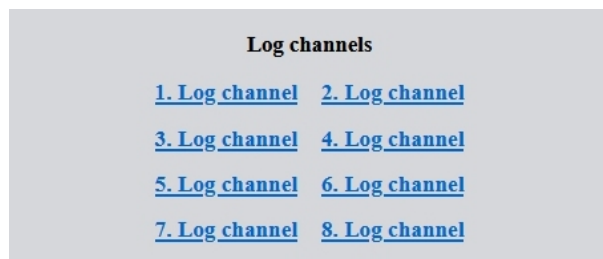

**Figure 10.14:** Overview, log channels

The parameter description is given in chapter 7.2.5 to be found on page 24.

Log channel 1	
Slave address	0
Register	40017
Data type	FPN ▾
Interval	1 s
Log enable	on ▾
Labeling	E1
Unit	mA

[return](#)

Figure 10.15: Example: Log channel 1

## 10.7.6 Log settings

Global log settings are made on this page.

The parameter description is given in chapter 7.2.6 to be found on page 25.

Log settings	
Log enable	off ▾
Log mode	Continuously ▾
Channel index	1
Switching threshold off	0,400 mA
Switching threshold on	0,600 mA
Trenddelta	1,000 mA
Trend timespan	10 s
once	01.12.2022 00:00:01 <b>Starttime</b>
once	01.12.2022 00:00:02 <b>Endtime</b>
daily	01.12.2022 00:00:03 <b>Starttime</b>
daily	01.12.2022 00:00:04 <b>Endtime</b>
Continuously	01.12.2022 00:00:00 <b>Starttime</b>

[return](#)

Figure 10.16: Global log settings

The unit of measurement of switching thresholds and trend is automatically determined via the channel index (log channel: 1..32).



*Time settings must be entered in the format shown here.*

## 10.7.7 Options

Global settings are made on this page. See chapter 7.2.7 on page 28

The user language for manual operation of the unit is set here.

For date, the complete string is used to set the real-time clock immediately.

Options	
Factory value Device reset?	<input type="checkbox"/>
Device reset? Observe the new IP address!	<input type="checkbox"/>
Password reset?	<input type="checkbox"/>
SD Card (> 60 days) Delete files	<input type="checkbox"/>
Language	English ▾
Brightness	50
Color scheme	Dark ▾
Autoscroll	5 s
Date	17.04.2023 15:51:55

[return](#)

**Figure 10.17:** Options

Functions can be activated here for execution after **save**.

- **Factory values**
- **Device restart**
- **Reset password**
- **File deletion** (all files, on the internal SD card, older than 60 days)
- **Language setting** (Menu navigation, basic unit)
- **Brightness** (10...100 Percent)
- **Color scheme**
- **Autoscroll time**



*Time settings must be entered in the format shown here.*



## 10.7.8 Configuration files

This page can be used to download the current device configuration as a file from the AD-VL 500 FE or to transfer existing files to the device. or existing files can be transferred to the unit. In this way, configuration data from different units can be mutually exchanged.

Configuration parameters and the characteristics table are handled separately.

When uploading to the AD-VL 500 FE , the unit automatically recognises the correct target file.

The files can also be transferred by means of a USB data carrier.

See chapter 7.2.11, on page 29.

The AD-VL 500 FE checks the files for compatibility. They must not be manipulated. Uploads with errors are answered with a message: **wrong file format**.

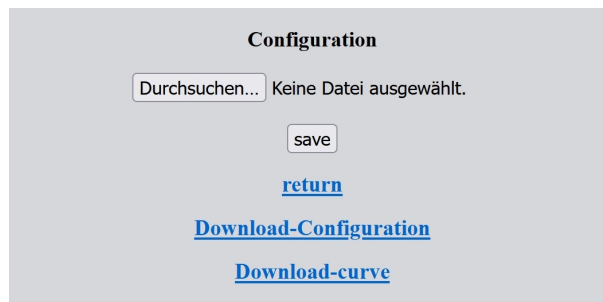

Figure 10.18: Configuration files

## 10.7.9 Network

The IP address can also be set up individually on this page.

The screenshot shows a web interface titled "Network". It contains a table for network settings:

IP-Address	192	168	50	230
Subnet	255	255	255	0
DHCP	on ▾			

Below the table is a "save" button and a blue "return" link.

Figure 10.19: Network settings

When switching to **DHCP = off**, automatic forwarding to the entered IP address takes place after a few seconds.

The accessing client must be in the same subnet.

When switching back to **DHCP = on**, the renewed address reference with a presumably unknown IP address must be observed.

The unit is currently not accessible. See chapter 10.8, on page 51.

## 10.7.10 RS485

The adjustment of the interface parameters may only be necessary when connecting units that were not supplied by Adamczewski elektronische Messtechnik GmbH .

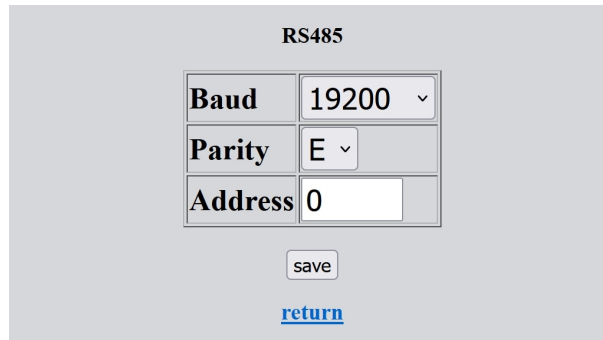

The screenshot shows a configuration window titled "RS485". It contains three rows of settings:

Baud	19200 ▾
Parity	E ▾
Address	0

Below the table are two buttons: "save" and "[return](#)".

**Figure 10.20:** RS485

## 10.8 Find devices in the network

All ADAMCZEWSKI units present in the local network can be accessed by means of the auxiliary programme **Find NETWORK-DEVICE** can be identified. This is necessary if the DHCP function has been set on a unit and the unknown IP address must be determined.

The programme package can be downloaded from the website:

<https://www.adamczewski.com/media/find-network-device.zip>

After unpacking the file and calling **setup.exe**, the programme is installed. In the process, confirm the required permissions in the firewall messages. The programme **Find NETWORK-DEVICE** requires network access.

When the programme is started, the unit messages of all units found are listed in a window. A unit message contains the unit name with the associated MAC address. In the following line, the link to the accessibility of the found units appears. In this way, the units can be localised in connection with their MAC address, which is also located on the unit.

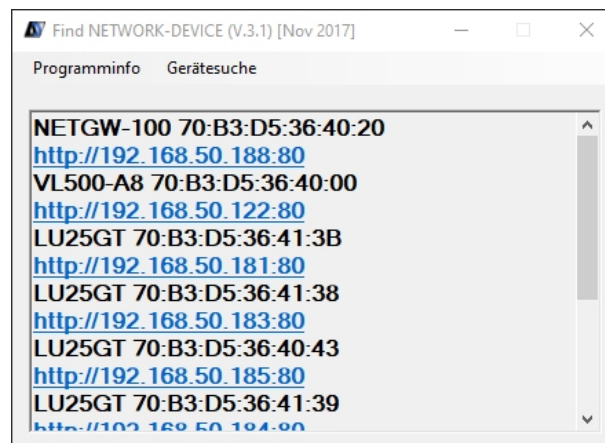

Figure 10.21: Device list

This information should be stored for later access.

### 10.8.1 Automated device call-up

By clicking on the link of the **VL500-A8**, the device start page can be called up. The system's own standard web browser is started automatically.

### 10.8.2 Manual unit call

The IP address in the text field is copied and pasted into the address bar of the web browser together with the configuration port (e.g. 192.168.50.122) into the address bar of the web browser. The unit appears with its start page.

# 11 Storage management and data formats of the files

## 11.1 Storage space management

The AD-VL 500 FE has implemented a memory management function that automatically prevents the internal SD card from overflowing. All log files older than 60 days will be deleted when a memory occupancy of 70 percent is reached. The check is carried out at the end of each day before a new daily file has to be created.

## 11.2 Data structure

The illustration 11.1 shows an example of the file system on the SD card as it is also transferred to a USB stick during backup. The name of the directory '1234567' is replaced by the production number of the unit. The log file '1234567.log' and the day files in the format 'YYYYMMDD.csv' are stored in this directory. A new day file is created with each day transition.

The file has the format 'CSV' (Comma Separated Values), separator is the semicolon ';':

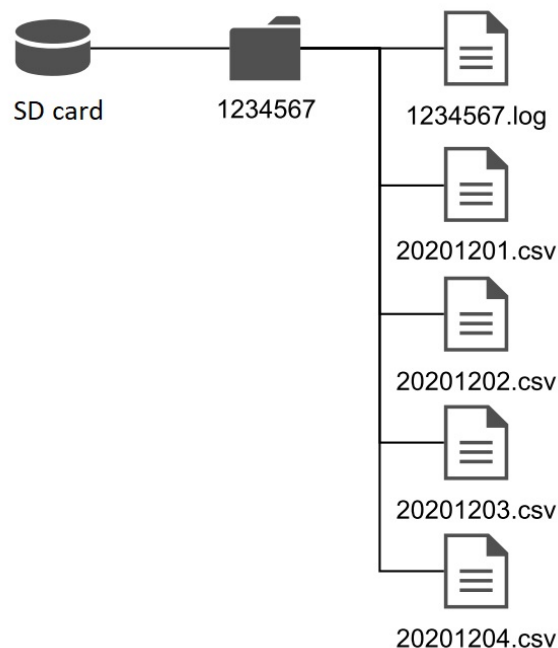

**Figure 11.1:** File system on the SD card

The day files have the following structure:

**Header** 'Timestamp;Channel1; ... ;Channel32'

'Timestamp' is the date and time in format 'TT.MM.JJJJ SS:MM:SS'.

'Channel1' ... 'Channel32' Label of the channel, how it was configured.

**Data line** '11.11.2011 11:11:11;1,2345;;;;;2,3456'

Channels that are not logged remain empty!

## 11.2.1 Memory requirements on the SD card

The memory required on the SD card depends mainly on the number of channels and the log interval. The internal SD card has 2GB storage capacity as standard. In the table, you can see the memory requirements in GB per year for your application.

Example: 8 channels are configured. According to the table, this means that a 2GB card would be full after one year with a log interval of 2 seconds.

**Table 11.1:** Memory requirement in GB/a depending on log interval and number of channels

Log-Int.[s]	1	2	3	4	8	12	16	20	24	28	32
1	1,85	2,14	2,44	2,73	3,91	5,08	6,26	7,43	8,61	9,78	10,96
2	0,93	1,07	1,22	1,37	1,95	2,54	3,13	3,72	4,30	4,89	5,48
3	0,62	0,71	0,81	0,91	1,30	1,69	2,09	2,48	2,87	3,26	3,65
4	0,46	0,54	0,61	0,68	0,98	1,27	1,56	1,86	2,15	2,45	2,74
5	0,37	0,43	0,49	0,55	0,78	1,02	1,25	1,49	1,72	1,96	2,19
6	0,31	0,36	0,41	0,46	0,65	0,85	1,04	1,24	1,43	1,63	1,83
7	0,26	0,31	0,35	0,39	0,56	0,73	0,89	1,06	1,23	1,40	1,57
8	0,23	0,27	0,30	0,34	0,49	0,64	0,78	0,93	1,08	1,22	1,37
9	0,21	0,24	0,27	0,30	0,43	0,56	0,70	0,83	0,96	1,09	1,22
10	0,19	0,21	0,24	0,27	0,39	0,51	0,63	0,74	0,86	0,98	1,10
20	0,09	0,11	0,12	0,14	0,20	0,25	0,31	0,37	0,43	0,49	0,55
30	0,06	0,07	0,08	0,09	0,13	0,17	0,21	0,25	0,29	0,33	0,37
40	0,05	0,05	0,06	0,07	0,10	0,13	0,16	0,19	0,22	0,24	0,27
50	0,04	0,04	0,05	0,05	0,08	0,10	0,13	0,15	0,17	0,20	0,22
60	0,03	0,04	0,04	0,05	0,07	0,08	0,10	0,12	0,14	0,16	0,18



*The period of one year for calculating the memory requirement is arbitrarily chosen. The data must be fetched before the memory card is full.*

## 11.3 Logfile

Device-specific data is saved in the log file, which can be used to evaluate the operating behaviour of the AD-VL 500 FE . A line is written with every device restart. It contains:

- a timestamp of the unit start time
- the memory card information with remaining memory and total capacity in kByte
- the timestamp of the last power failure
- the Device firmware status

# 12 Maintenance and servicing

During proper operation of the AD-VL 500 FE , it is maintenance-free. The measuring system of the devices also works stably over long periods of time. Regular adjustment or similar is therefore not necessary. No other maintenance work is required either. As soon as malfunctions of the unit are noticed, remove the unit. The internal parts of the unit cannot be serviced by the customer. In case of damage, the units may only be repaired by the manufacturer. Send the unit to the Adamczewski elektronische Messtechnik GmbH to have it serviced by the manufacturer.

## 12.1 Firmwareupdate

In the course of further technical developments, it may be necessary to update the specific device properties to a new status.

For this purpose there is the possibility to transfer a new firmware to the unit by means of a personal computer (with Windows operating system).

The required interface converter **AD-VARIO-PASS** and a data cable can be obtained from Adamczewski elektronische Messtechnik GmbH .

The device update of the AD-VL 500 FE with a new firmware is basically only possible by means of the Configuration software AD-Studio via the AD-UART interface.

The current device firmware can be downloaded and saved with this software.

This download takes place automatically when a firmware update is carried out with the Configuration software AD-Studio and there is an online connection to the Internet.

The file name in lower case must correspond to the following

format: **v1500-a8-1-2.bin!** The numbers 1 and 2 indicate, for example, the firmware version V.1.2 and can change continuously.

If necessary, the unit parameters should be saved with the Configuration software AD-Studio before a firmware update. Alternative configuration backups are described in chapter 7.2.11, page 29 and chapter 10.7.8, page 49.



*The transfer of foreign or incorrect device firmware to the connected device will result in the device becoming inoperable. In this case, the unit must be returned to the manufacturer.*



*A supply voltage failure during the update process can result in a malfunction. In this case, the unit must be returned to the manufacturer.*

### 12.1.1 Firmwareupdate with Configuration software AD-Studio

Update procedure:

- 1 Connect the unit to the power supply and connect it to the PC via a serial data cable.
- 2 Start Configuration software AD-Studio .
- 3 Select and connect the AD-VL 500 FE device.
- 4 Menu selection ⇒ Extras ⇒ Firmware update ⇒ Execute desired sub-function.
- 5 Wait until the firmware update is complete. Do not disconnect the device and do not interrupt the data transmission. This process takes a few minutes. Afterwards, a device restart is carried out.

### 12.1.2 Firmware update with USB data carrier

The required menu branch for this function is only available when the USB data carrier is plugged in, from a unit firmware version 1.2. During the update process, no unit functions are executed and the firmware file is checked for validity. The firmware file must be located in the root directory of the data carrier. The file name should not be changed. Several file names of the same type in the main directory are not permitted. The process must be waited for and cannot be aborted prematurely. be terminated prematurely.

Update procedure:

- 1 Transfer the firmware file **vl500-a8-1-2.bin** to a USB data carrier.
- 2 Insert the USB data carrier into the unit. Wait until registration.
- 3 Menu selection ⇒ Options ⇒ Firmwareupdate ⇒ select **yes**
- 4 Observe the messages of the update process in the display.  
The whole process takes a few seconds.
- 5 The message **please wait** in red and yellow indicates the update progress.
- 6 A red error message **File error** indicates an invalid file.  
The update process is aborted. This error message must be acknowledged.
- 7 After a successful device update, the device AD-VL 500 FE performs a restart and continue working immediately.
- 8 When the unit starts up, a message appears in the first line of the unit display.:  
**Firmwareupdate OK.**
- 9 The firmware update process is completed.

### 12.1.3 Firmware update via network (LAN)

The required menu branch for this function is only available from a unit firmware version 1.2. The local storage location of the new firmware file should be known. During the update process, no unit functions are executed and the firmware file is checked for validity. The file name should not be changed. The file upload must be waited for. The process cannot be aborted prematurely. be terminated prematurely.



**Figure 12.1:** Firmware update via network

Update procedure:

- 1 Call up the web interface of the AD-VL 500 FE and select the desired target language (enter access data if necessary).
- 2 Call up the link **device information**.
- 3 The term **firmware** shown as a link on this page must be clicked.
- 4 The firmware file is selected via the following input mask and transferred to the unit.
- 5 Note the messages of the update process in the browser window.  
The entire process does not take a minute.
- 6 An error message **file error** indicates an invalid file and the update process is cancelled.
- 7 After a successful device update, the device AD-VL 500 FE restarts and continues to work immediately.
- 8 When the unit starts up, a message appears in the first line of the unit display.:  
**Firmwareupdate OK.**
- 9 The web browser is automatically redirected to the **device information** page again.
- 10 The firmware update process is completed.



# 13 Help with faults

When errors occur, the connection circuit should always be checked. The **device information** on the unit provides a lot of information for self-diagnosis. The following table contains information on troubleshooting. If the help listed here does not lead to success, there is probably a hardware fault. In this case, please send the unit to the manufacturer.

Error	Possible cause	Solution
Display dark	Brightness set low	Set up brightness
Count values are missing or wrong	Pulse width too narrow, incorrect valuation	Extend pulse time, Correct factor/divider
Current signal value too high	Input resistance interrupted at the canal	Check (50 $\Omega$ ) Measure input current
Voltage signal value missing	Input resistance interrupted at the canal	Check (100 k $\Omega$ ) Measure input voltage
No current or voltage signal	Polarity reversed, incorrect channel assignment	checkn and correct
ADC error display in red color	AD converter defective, Hardware error	Send the unit to the manufacturer
MB Error display in red color	RS-485-Bus-Hardware, RS-485-Parameter, Configuration error	Correct the Log log-channel setup or the RS-485 parameters
No data on the RS-485-Bus, sporadic data errors	A/B reversed, or incorrect device addresses, terminating resistor missing	Correct channel setup or change A/B, clamp on both sides 120 $\Omega$
AD-UART-connection not possible	AD-VARIO-PASS not installt	Install driver or correct
MB Error display not green	No log channe (1...32) set up	Complete log channel setup
Internal SD card not recognised/available	Hardware error	Send the unit to the manufacturer
External USB stick not recognised/available	USB stick defective or not/incorrectly formatted	Use another data carrier, reformat
No log data generated	global log release not activated or trigger-condition not met	Activate log release, Correct trigger condition
Date or time Not adjustable	Hardware error	Send the unit to the manufacturer
LAN indicator is not green	No network connection, DHCP server missing on the network	Establish LAN connection, Set fixed IP address
Device in the network not availabler	Device or client are in the wrong subnet	Correct settings
Device serial number contains 9999999	Device calibration data faulty	Contact manufacturer, Remote repair possible

# 14 Appendix

## 14.1 Address of the manufacturer

If you have any questions about the product, requests or suggestions, please contact the manufacturer of the product directly:

Adamczewski elektronische Messtechnik GmbH  
Felix-Wankel-Strasse 13  
74374 Zaberfeld  
Telefon: 07046/875  
Telefax: 07046/7678  
E-Mail: info@ad-messtechnik.de  
Internet: www.adamczewski.com

## 14.2 Data evaluation

The day files can be read into common spreadsheet programs. In addition, the Adamczewski elektronische Messtechnik GmbH provides a free utility for merging these individual files into one overall file:

<https://www.adamczewski.com/media/dateiverkettung.zip>

## 14.3 Device operating instructions

The current device operating manual of the AD-VL 500 FE is available under the following link:

<https://www.adamczewski.com/manual/man-vl500-ad-en.pdf>

## 14.4 Device data sheet

The current device data sheet of the AD-VL 500 FE is available under the following link:

[https://www.adamczewski.com/media\\_pdf/en/vl500fe.pdf](https://www.adamczewski.com/media_pdf/en/vl500fe.pdf)

### Revisions

Revision	Date	Remarks
1.0	2023-04-05	Start version of the documentation
1.1	2023-07-12	Description firmware update
1.2	2023-12-05	Layout optimization
1.3	2024-02-07	Device can be written to as MB slave; 7-digit-counter