

## Description

The digital power converter AD-LU 451 GT-PN measures all values of the three-phase power grid such as current, voltage, energy, active, reactive, apparent power and frequency and makes this data available via a fieldbus. The device is therefore ideally suited for integration into energy management systems. The AD-LU 451 GT-PN has a ProfiNet interface with a 2-port switch for direct looping to the next device. 3- or 4-wire networks can be measured. 4-wire networks may have balanced or unbalanced load. 3-wire networks must have balanced load. The integrated wide-range power supply enables operation over a wide supply voltage range. The current measurement takes place via external split-core current transformers, which can be mounted on the wire to be measured without cutting. For the measurement of higher voltages, external converters can be connected at any time. LEDs on the front panel signal the operating state and the data traffic. The compact design and the high performance combined with low energy consumption allow it to be used in almost any application. In addition, the device has a front-sided RS485 interface to which, for example, the TFT display AD-MM 400 can be connected. Thus, without any great effort, all measured values can be displayed.

## Application

Measurement and monitoring of all electrical characteristics in electrical systems. Detection of load profiles for energy management systems, e.g. ISO 50001. Recording the energy consumption of individual consumers. Monitoring of voltage quality variables, e.g. Harmonics. Attention: This is a Class A product according to EN 55011. Additional EMC actions may be necessary when used in small businesses or in residential areas.



## Specific characteristics

- Connection of 4-wire systems of any load
- Measurement of currents, voltages, power, power factors, frequency, harmonics
- Low power loss during current measurement thanks to external split-core transformers
- Counters for applied and feedback energies
- Counters for inductive and capacitive reactive power
- Fieldbus interface for PROFINET
- RS485 interface for connecting a TFT display
- Supply via wide-range power supply
- Configuration of current and voltage transformers only via Profinet

## Business data

### Order number

AD-LU 451 GT-PN      PROFINET

### Accessory

AD-MM 400 FE	TFT display for front panel installation
AD-MM 500 FE	TFT display for front panel installation including data logging
AD-KSW 50	50 A split-core-transformer
AD-KSW 100	100 A split-core-transformer
AD-KSW 200	200 A split-core-transformer
AD-KSW 400	400 A split-core-transformer
AD-KSW 600	600 A split-core-transformer

## Information

### Downloads

PROFINET File	<a href="#">AD-LU451GT-GSD.zip</a>
Tender text	<a href="#">lu451gt-pn.zip</a>
Basic knowledge of power and energy measurement technology	<a href="#">lu-grundbegriffe.pdf</a>
Safety instructions	<a href="#">ad-safety-instructions.pdf</a>

## Technical specifications

### Current-inputs (I1...I3)

Measuring ranges	0 ... 33,3 mA (over split-core-transformer)
Input resistance	ca. 10 Ohm
Max. measurable harmonic	40

### Voltage-inputs (L1...L3)

Measuring range	0 ... 253 V AC
Input resistance	ca. 970 kOhm

### PROFINET

Ethernet	2 Port Switch
Protocol specification	PROFINET IO
Default IP-address	0.0.0.0

### RS485-Bus

Software protocol	Modbus-RTU
Data format	19200, e, 8, 1
Max. bus users	99
Bus termination	120 ohms both sides at the end

Max. length of bus	500 m (no spur lines)
Cable	twisted and shielded
Address setting	BCD-switches 00...99
Broadcast address	0

### Supply

Voltage range AC	50 ... 253 V AC, 50/60 Hz
Voltage range DC	20 ... 253 V DC
Nominal voltage AC/DC	230 V AC / 24 V DC
Input power AC/DC	max. 4 VA / 3 W

### Measure

Basic accuracy	$\leq 0,5\%$ (class 0.5)
Temperature influence	80 ppm/K
Sampling interval	200 ms

### Housing

Dimensions (WxHxD)	105x90x60 mm
Type of protection	IP 20
Connection method	screw clamp
Terminals, wire cross section	2,5 mm <sup>2</sup> flex wire / 4 mm <sup>2</sup> one wire
Bolting torque terminals	0,6 Nm
Weight	~400g
Manner of fastening	35 mm DIN rail 35mm
Skimming length	6mm

### Environmental conditions

Ambient temperature	-10 ... 60 °C
Storage and transport	-10 ... 70 °C (no condensation)

### EMC

Product family standard	EN 61326-1 <sup>1)</sup>
Emitted interference	EN 55011, CISPR11 Cl. A, Gr. 1

<sup>1)</sup> During checking, slight signal deviations are possible.

### Electrical safety requirements

Product family standard	EN 61010-1
Overvoltage category	II
Pollution degree	2
Safety measurement	EN 61010-2-030
Measurement category	CAT III

### Galvanic isolation, test voltages

Grid side zu bus	4 kV, 50 Hz (1 min.)
Grid side to control elements	4 kV, 50 Hz (1 min.)

### Block and wiring diagram

### Dimensions

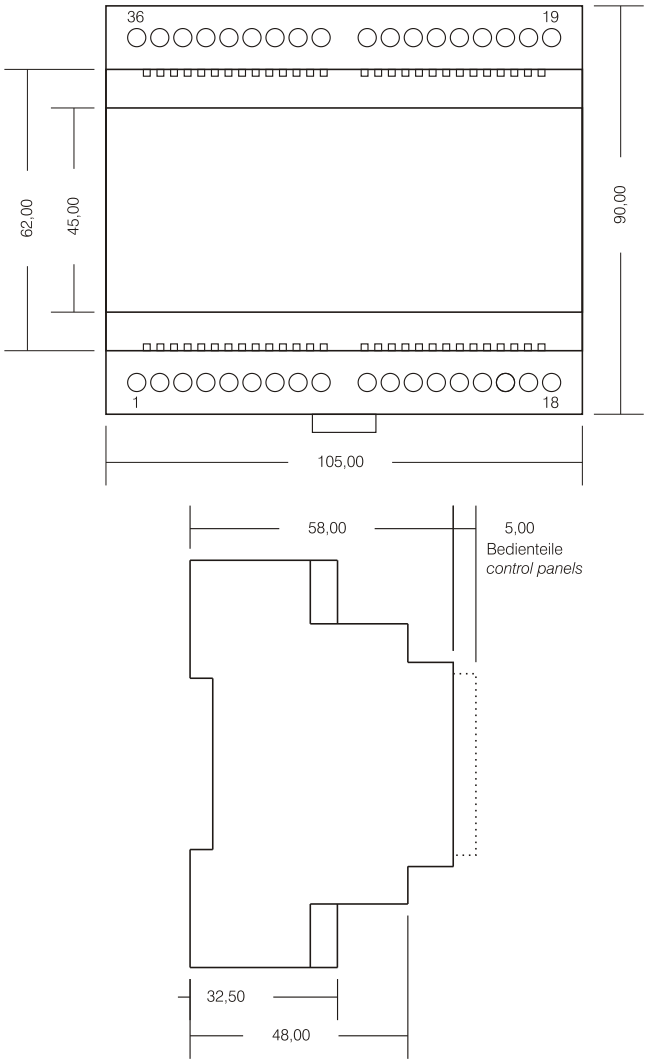
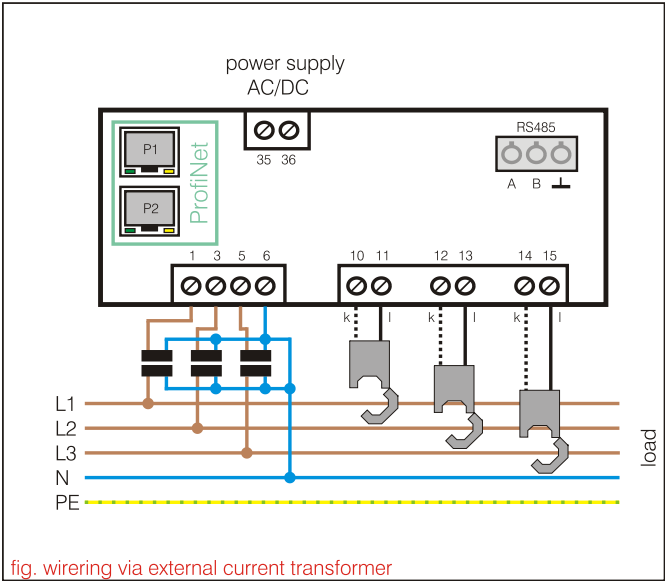
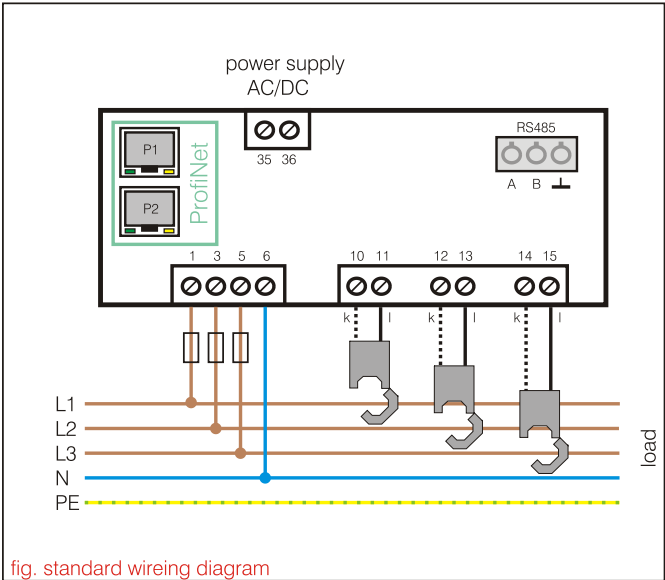

### Explanations:

#### PROFINET: NS-Led (Network Status):

The NS-LED signals the network status.

LED Status:	Description:	Comments
off	Offline	- no Power - no connection with IO-Controller
green	Online RUN	- connection with IO-Controller established - IO-Controller in RUN Status
green - 1 flash	Online STOP	- connection with IO-Controller established - IO-Controller in STOP Status - IO-data bad - IRT synchronization not finished
green - blinking	link mode	- Uses by engineering tools to identify the node on the network
red	fatal event	- Major internal error
red - 1 flash	station name error	- Station name not set
red - 2 flash	IP-Address error	- IP-address not set
red - 3 flash	configuration error	- Expected identification differs from real identification

#### PROFINET: MS-Led (Modul Status):

The MS-LED signals the status of the ProfiNet module in the power meter.

LED Status:	Description:	Comments
off	not initialized	- Nor power or module in "SETUP" or "NW-INIT" state
green	normal operation	- Modul has shifted from "NW-INIT" state
green - 1 flash	diagnostic event	- diagnostic event present
red	exception error or fatal event	- Device in state EXCEPTION or major internal error
alternating red/green	firmwareupdate	- Do not power off the modul - turning the module off during this phase could cause permanent damage

## Modbus-Data (RS485-bus)

### Messwerte:

address	count register	name	unit	type	read	write
40801	2	TOTAL_ACTIVE_POWER	kW	float	1	0
40803	2	PHASE_A_ACTIVE_POWER	kW	float	1	0
40805	2	PHASE_B_ACTIVE_POWER	kW	float	1	0
40807	2	PHASE_C_ACTIVE_POWER	kW	float	1	0
40809	2	TOTAL_REACTIVE_POWER	kvar	float	1	0
40811	2	PHASE_A_REACTIVE_POWER	kvar	float	1	0
40813	2	PHASE_B_REACTIVE_POWER	kvar	float	1	0
40815	2	PHASE_C_REACTIVE_POWER	kvar	float	1	0
40817	2	TOTAL_APPARENT_POWER	kVA	float	1	0
40819	2	PHASE_A_APPARENT_POWER	kVA	float	1	0
40821	2	PHASE_B_APPARENT_POWER	kVA	float	1	0
40823	2	PHASE_C_APPARENT_POWER	kVA	float	1	0
40825	2	TOTAL_POWER_FACTOR		float	1	0
40827	2	PHASE_A_POWER_FACTOR		float	1	0
40829	2	PHASE_B_POWER_FACTOR		float	1	0
40831	2	PHASE_C_POWER_FACTOR		float	1	0
40833	2	TOTAL_ACTIVE_FUNDAMENTAL_POWER	kW	float	1	0
40835	2	PHASE_A_ACTIVE_FUNDAMENTAL_POWER	kW	float	1	0
40837	2	PHASE_B_ACTIVE_FUNDAMENTAL_POWER	kW	float	1	0
40839	2	PHASE_C_ACTIVE_FUNDAMENTAL_POWER	kW	float	1	0
40841	2	TOTAL_ACTIVE_HARMONIC_POWER	kW	float	1	0
40843	2	PHASE_A_ACTIVE_HARMONIC_POWER	kW	float	1	0
40845	2	PHASE_B_ACTIVE_HARMONIC_POWER	kW	float	1	0
40847	2	PHASE_C_ACTIVE_HARMONIC_POWER	kW	float	1	0
40849	2	PHASE_A_VOLTAGE_RMS	V	float	1	0
40851	2	PHASE_B_VOLTAGE_RMS	V	float	1	0
40853	2	PHASE_C_VOLTAGE_RMS	V	float	1	0
40855	2	N_LINE_CALCULATED_CURRENT_RMS	A	float	1	0
40857	2	PHASE_A_CURRENT_RMS	A	float	1	0
40859	2	PHASE_B_CURRENT_RMS	A	float	1	0
40861	2	PHASE_C_CURRENT_RMS	A	float	1	0
40863	2	CHANNEL_A_VOLTAGE_PEAK	V	float	1	0
40865	2	CHANNEL_B_VOLTAGE_PEAK	V	float	1	0
40867	2	CHANNEL_C_VOLTAGE_PEAK	V	float	1	0
40869	2	CHANNEL_A_CURRENT_PEAK	A	float	1	0
40871	2	CHANNEL_B_CURRENT_PEAK	A	float	1	0
40873	2	CHANNEL_C_CURRENT_PEAK	A	float	1	0
40875	2	FREQUENCY	Hz	float	1	0
40877	2	PHASE_A_MEAN_PHASE_ANGLE	°	float	1	0
40879	2	PHASE_B_MEAN_PHASE_ANGLE	°	float	1	0
40881	2	PHASE_C_MEAN_PHASE_ANGLE	°	float	1	0
40883	2	PHASE_A_VOLTAGE_PHASE_ANGLE	°	float	1	0
40885	2	PHASE_B_VOLTAGE_PHASE_ANGLE	°	float	1	0
40887	2	PHASE_C_VOLTAGE_PHASE_ANGLE	°	float	1	0
40889	2	MEASURED_TEMPERATURE	°C	float	1	0
40891	2	PHASE_AB_VOLTAGE_RMS	V	float	1	0
40893	2	PHASE_BC_VOLTAGE_RMS	V	float	1	0
40895	2	PHASE_CA_VOLTAGE_RMS	V	float	1	0

### Zähler:

address	count register	name	unit	type	read	write
44009	2	ENERGY_KWH_TOTAL_CONSUMPTION	kWh	U32	1	1
44011	2	ENERGY_KWH_TOTAL_INFEED	kWh	U32	1	1
44013	2	ENERGY_KVARH_TOTAL_INDUCTIVE	kVarh	U32	1	1
44015	2	ENERGY_KVARH_TOTAL_CAPACITIVE	kVarh	U32	1	1
44017	2	ENERGY_KVAH_TOTAL	kVAh	U32	1	1
44019	2	WORKING HOURS	h	U32	1	1
44021	2	LOAD HOURS	h	U32	1	1

## Circuit examples

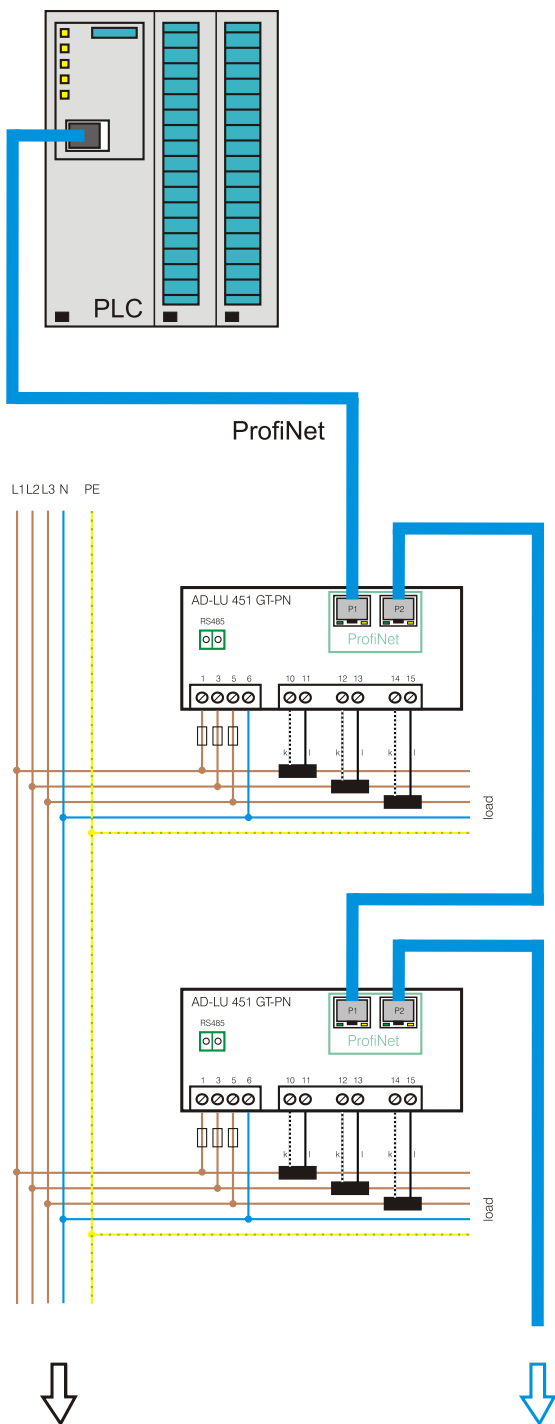

## ProfiNet/ProfiBus Data

P Total [kW]	float	4 Byte	Read	
P L1 [kW]	float	4 Byte	Read	
P L2 [kW]	float	4 Byte	Read	
P L3 [kW]	float	4 Byte	Read	
Q Total [kvar]	float	4 Byte	Read	
Q L1 [kvar]	float	4 Byte	Read	
Q L2 [kvar]	float	4 Byte	Read	
Q L3 [kvar]	float	4 Byte	Read	
S Total [kVA]	float	4 Byte	Read	
S L1 [kVA]	float	4 Byte	Read	
S L2 [kVA]	float	4 Byte	Read	
S L3 [kVA]	float	4 Byte	Read	
Power Factor Total	float	4 Byte	Read	
Power Factor L1	float	4 Byte	Read	
Power Factor L2	float	4 Byte	Read	
Power Factor L3	float	4 Byte	Read	
P Fundamental Total [kW]	float	4 Byte	Read	
P Fundamental L1 [kW]	float	4 Byte	Read	
P Fundamental L2 [kW]	float	4 Byte	Read	
P Fundamental L3 [kW]	float	4 Byte	Read	
P Harmonic Total [kW]	float	4 Byte	Read	
P Harmonic L1 [kW]	float	4 Byte	Read	
P Harmonic L2 [kW]	float	4 Byte	Read	
P Harmonic L3 [kW]	float	4 Byte	Read	
U L1 [V]	float	4 Byte	Read	
U L2 [V]	float	4 Byte	Read	
U L3 [V]	float	4 Byte	Read	
Calculated I N-LINE [A]	float	4 Byte	Read	
I L1 [A]	float	4 Byte	Read	
I L2 [A]	float	4 Byte	Read	
I L3 [A]	float	4 Byte	Read	
Peak U L1 [V]	float	4 Byte	Read	
Peak U L2 [V]	float	4 Byte	Read	
Peak U L3 [V]	float	4 Byte	Read	
Peak I L1 [A]	float	4 Byte	Read	
Peak I L2 [A]	float	4 Byte	Read	
Peak I L3 [A]	float	4 Byte	Read	
Frequency [Hz]	float	4 Byte	Read	
Angle I L1 [°]	float	4 Byte	Read	
Angle I L2 [°]	float	4 Byte	Read	
Angle I L3 [°]	float	4 Byte	Read	
Angle U L1 [°]	float	4 Byte	Read	
Angle U L2 [°]	float	4 Byte	Read	
Angle U L3 [°]	float	4 Byte	Read	
Counter total extract [kWh]	dword	4 Byte	Read	
Counter total feed [kWh]	dword	4 Byte	Read	
Counter total ind [kvarh]	dword	4 Byte	Read	
Counter total cap [kVarh]	dword	4 Byte	Read	
Counter total apparent power [kVAh]	dword	4 Byte	Read	
Counter working hours [h]	dword	4 Byte	Read	
Param I PRIM [A]	float	4 Byte	Read/Write	
Param I SEC [A]	float	4 Byte	Read/Write	
Param U PRIM [V]	float	4 Byte	Read/Write	
Param U SEC [V]	float	4 Byte	Read/Write	
Control Word	(*1)	word	2 Byte	Write
Status Word	(*2)	word	2 Byte	Read
Serial Number		dword	4 Byte	Read
Firmware Version		word	2 Byte	Read
Language		word	2 Byte	Read

Control Word	(*1)	Bit 15	Bit 14	Bit 13	Bit 12	Bit 11	Bit 10	Bit 9	Bit 8	Bit 7	Bit 6	Bit 5	Bit 4	Bit 3	Bit 2	Bit 1	Bit 0
		—	—	—	—	—	—	—	—	—	—	—	—	—	—	Counter Reset	Softw. Reset
Status Word	(*2)	Bit 15	Bit 14	Bit 13	Bit 12	Bit 11	Bit 10	Bit 9	Bit 8	Bit 7	Bit 6	Bit 5	Bit 4	Bit 3	Bit 2	Bit 1	Bit 0
		—	—	—	—	—	—	—	—	—	High Temp.	I3 Overfl.	I2 Overfl.	I1 Overfl.	L3 Error	L2 Error	L1 Error